

DO NOT THROW AWAY

IMPORTANT MANUAL

MODEL T-4 TRENCHER



Operators Manual



P.O.BOX 290 • San Bernardino, CA. 92402

Phone (909) 478-5700 • (800) 922-4680 • Fax (909) 478-5710

E-mail: sales@groundhoginc.com • www.groundhoginc.com



WARNINGS AND SAFETY INSTRUCTIONS

 This symbol means **DANGER, WARNING or CAUTION**. Personal injury and/or property damage may occur unless instructions are followed carefully.

WARNING ~ THIS POWER TOOL CAN BE DANGEROUS!

This tool can cause serious injury to the operator and bystanders. The warning and safety instructions in this manual must be followed to provide reasonable safety and efficiency in using and storing this trencher. The operator is responsible for following the warnings and instructions in this manual and the trencher. **Read the entire Operator's Manual before using this trencher! Restrict the use of this trencher to persons who read, understand, and follow the warnings and instructions in this manual and on the trencher. If you have not read and understand the warnings and instructions in this manual and on the trencher, you are not qualified to operate this trencher!**

 This product contains and/or emits chemicals known to the State of California to cause cancer, birth defects or other reproductive harm. This statement is made in compliance to California Proposition 65.

DANGER

- Keep body parts, foreign objects and clothing clear of rotating auger and digging chain.
- Coming into contact with buried utilities while digging can cause severe injuries or DEATH.
- Contact appropriate utility representatives to determine if/where electrical cables, gas lines, water lines, etc. are buried BEFORE operation.



**Know what's below.
Call before you dig.**



WARNINGS AND SAFETY INSTRUCTIONS cont'd...

OPERATOR SAFETY

1. Always wear the proper clothing and protective gear for the job. Eye and ear protection, hard hat, boots, gloves and dust masks are some of the items that may be required.
2. Keep hair, fingers, and all other body parts away from openings and moving parts. Always wear, long pants, boots, and gloves. Do not wear loose clothing, jewelry, short pants, sandals or go barefoot. Secure hair so it is above shoulder length.
3. Do not operate this trencher indoors. For outdoor use only.
4. Do not operate this trencher when you are tired, ill, or under the influence of alcohol, drugs, or medication.
5. Always assume the digging location contains underground utilities or obstructions. Contact appropriate utility company to determine if/where electrical cables, gas lines, water lines, etc. are buried BEFORE operation.
6. Always use extreme caution while operating this tool. Be sure of your footing and physical capabilities.

TOOL SAFETY

1. Inspect the entire trencher before each use. Replace damaged or worn parts.
2. Check for fuel leaks and make sure all fasteners are in place and securely fastened. Repair or replace as needed.
3. Replace digging blades that are severely worn, missing or damaged in any way before using this tool.
4. Be sure the digging chain is not moving when engine is at an idle.
5. Use only accessories or parts as recommended by Ground Hog, Inc.

FUEL SAFETY

1. Refuel outdoors only and where there are no sparks and flames.
2. Store fuel in a container approved for gasoline.
3. Do not smoke or allow smoking near fuel or the trencher or while using the trencher.
4. Clean up all fuel spills before starting engine.
5. Move at least 10 feet away from fueling site before starting engine.
6. Stop engine before removing fuel cap.
7. Store the trencher and fuel in an area where fuel vapors cannot reach sources of combustion like water heaters, electric motors, switches, furnaces, etc.

DIGGING SAFETY

1. Always assume the digging location contains buried underground utilities or obstructions. Call 811 to determine if/where electrical cables, gas lines, water lines, etc. are buried BEFORE operation.
2. Always be sure that the area you are going to trench in is clear of potential hazards, such as pipes, rocks, wire, boards or any other materials that could possibly entangle itself around the digging chain or cause unstable footing before using the trencher.
3. Keep others including children, animals, bystanders and helpers outside a 15 foot hazard zone from the trencher.
4. Hold the trencher handlebar firmly with both hands.
5. Keep all parts of your body and clothing away from the digging chain, auger and other moving parts.
6. Inspect the digging site. Soil conditions, job specifications and operator experience may dictate that a different trencher or method be used to do the job.
7. Do not leave trenches open or unmarked.

MAINTENANCE SAFETY

1. Maintain this trencher according to recommended procedures included in this manual.
2. Disconnect the spark plug wire before performing maintenance. See engine manual.
3. Stop engine before removing fuel cap.
4. Use only genuine replacement parts as recommended by Ground Hog or the engine manufacturer.

TRANSPORTATION AND STORING SAFETY

1. Always shut off the fuel valve and engine before transporting or storing.
2. Always allow the engine to cool before transporting or storing.
3. Store trencher and fuel in an area where fuel vapors cannot reach sources of combustion like, water heaters, electric motors, switches, furnaces, etc.
4. Always secure this trencher with tie downs or similar restraints when transporting.
5. The trencher shall be stored in a manner that prevents it from falling, rolling or tipping over.



INTRODUCTION

It is your responsibility as the operator of this piece of equipment to know what specific requirements, precautions and work hazards exist. You must read and understand all of the information contained in the operators manual.

The Ground Hog model T-4 trencher is a small, operator propelled, chain-type trencher designed for the installation of lines that require a narrow shallow trench.

The T-4 trencher has more than enough power to trench through the toughest soils, however, because of its small size, low horse power and trenching capacity, it is limited in what it is capable of doing. The job site, soil conditions, job specifications and operator experience may dictate that a different tool or method be used to do the job.

The digging chain of any trencher has a tendency to pull the trencher in the opposite direction you want to dig. For this reason, be sure that the digging teeth are not in contact with the ground or other objects while starting the engine and that the wheel lock device engages before lowering the digging bar into the ground. Be sure that you have a firm grip on the machine and are ready to control it when the digging bar comes in contact with the ground.

Trenchers of all type have a tendency to “hop” or “buck” under certain conditions. This can be the result of certain soil conditions or buried objects that the trencher cannot cut through or lift to the surface. The trencher must be stopped and the object removed, or restart the trench beyond the object.

NOTE: It is important that any piece of machinery be kept in the best mechanical condition possible. Failure to properly maintain machinery greatly reduces the productivity of the tool and could create a hazard to the operator or bystanders. **DO NOT** use machinery if it has been modified or improperly maintained.



KEY POINTS OF THE T-4

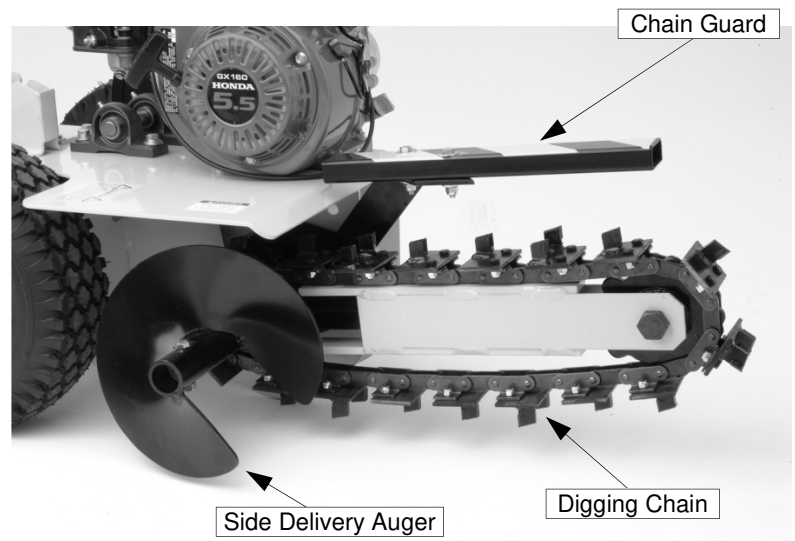
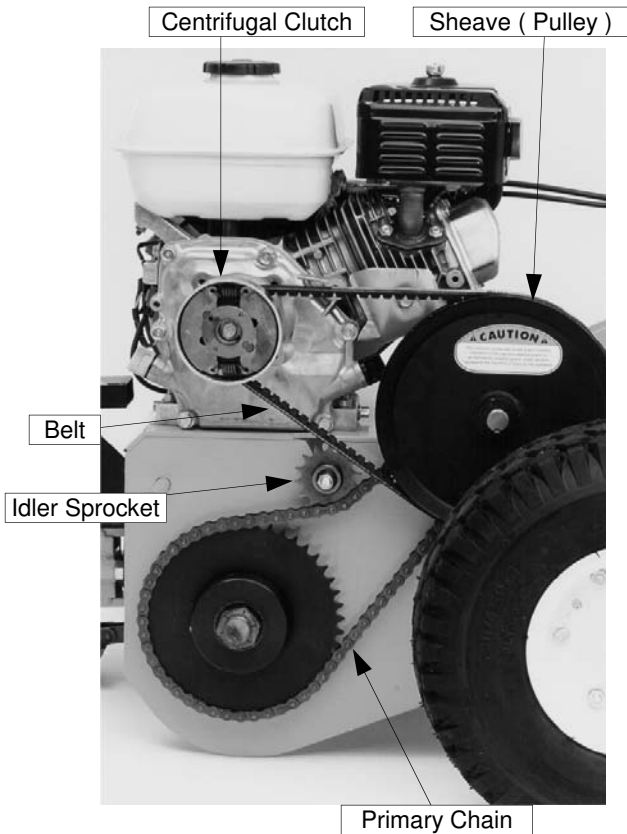
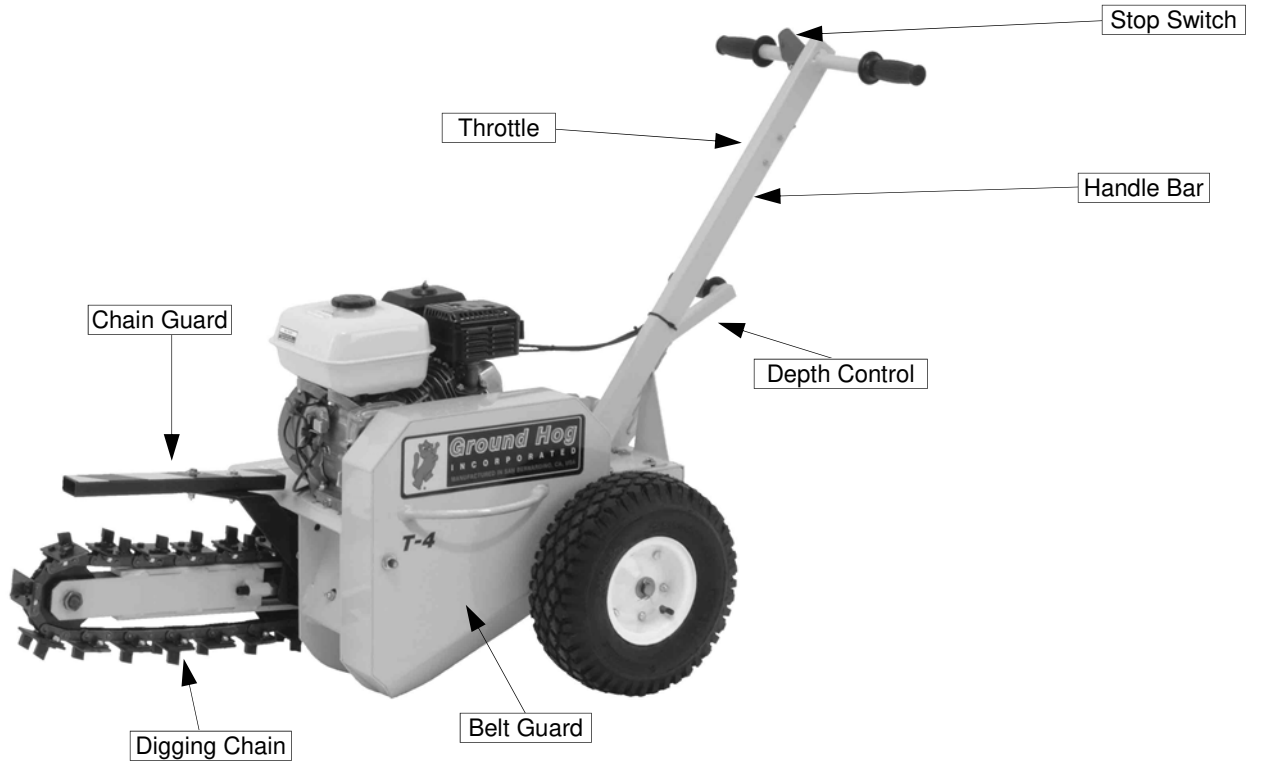

OPERATING INSTRUCTIONS

DANGER

Determine that the trencher is in its original, factory configuration and has not been modified or damaged and is not missing parts in any way. If there are any questions about possible modifications made to the trencher, do not use until the modifications have been corrected using only genuine replacement parts as recommended by Ground Hog or the engine manufacturer.

STOPPING THE T-4

There are two stop switches on the trencher; one on the handle bar and one on the engine. Refer to the engine manual for the switch location on your particular trencher. The operator can turn the trencher off at any time by switching either stop switch to the "OFF" position. Both switches must be "ON" before the engine can start.

DANGER

Keep bystanders clear. If the throttle is set higher than idle when the engine is running, the digging chain and other components will move.

Do not operate this trencher indoors. For outdoor use only.

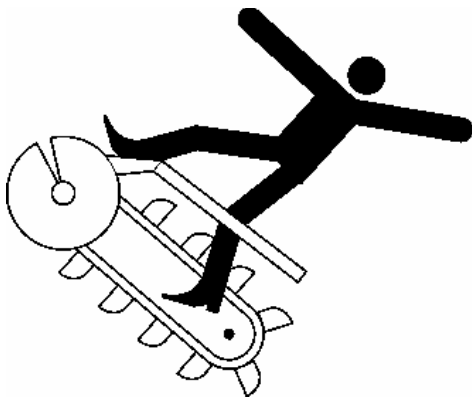

WARNING

Hitting a buried object, such as a rock, could cause a sudden thrust to the operator. Injury could occur if the operator is not prepared to deal with this condition.

STARTING THE T-4

1. Be sure the depth control is in the "0" depth position and move both stop switches to the "ON" position.
2. Always stand to the rear of the trencher, away from the side delivery auger and digging chain while starting the engine.
3. Start the engine following the procedures outlined in the engine manual supplied with the trencher.
4. Always start the trencher at the job site and allow it to warm up. While the machine is running, check that all controls are working properly before using.

TRENCHING

NOTE: The T-4 trencher is not self propelled.

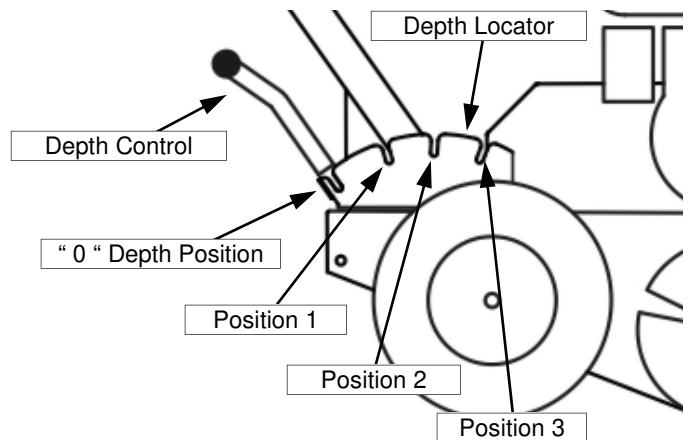

Depth Position	12" trencher	18" trencher
Position 1	6"	8"
Position 2	8"	12"
Position 3	12"	18"

NOTE: All depths are approximate. Actual depth may vary depending upon soil conditions and trencher blade wear.



OPERATING INSTRUCTIONS cont'd...

WARNING

Be sure the digging chain is not turning when the engine is at an idle.

Be sure the engine is off or at an idle before moving the trencher at the job site.

1. With the engine running and at an idle and the depth control in the "0" depth position, apply downward pressure on the handlebar raising the digging chain.

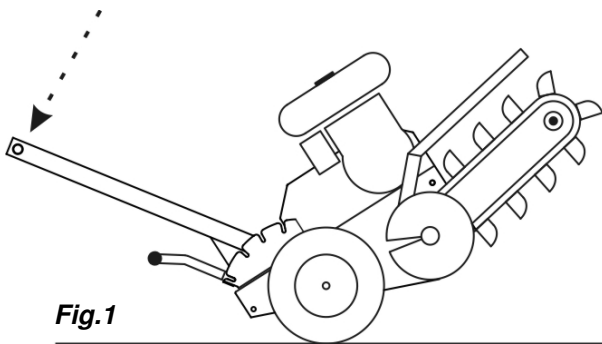

Fig.1

2. Lift the depth control handle and slowly move the lever forward into the desired depth notch. **Fig. 2**

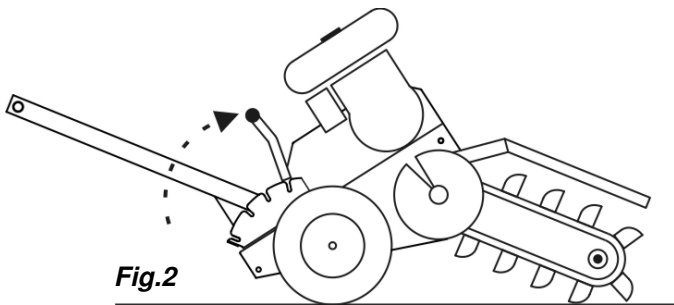

Fig.2

3. Apply downward pressure to the handlebar so the digging chain is not in contact with the ground. Increase the engine speed and hold on to the handlebar with both hands. Slowly relieve the downward pressure on the handlebar allowing the digging chain to penetrate the soil until the chosen depth is reached. **Fig. 3**

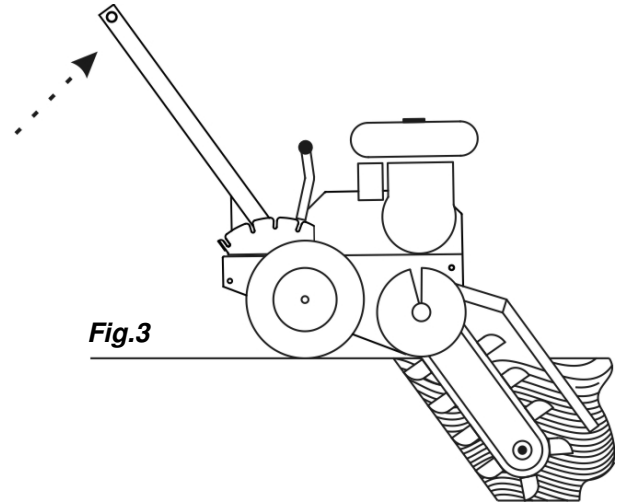

Fig.3

4. Using an intermittent pulling action, pull the trencher toward you 4 to 6 inches then relax your pull, allowing the trencher to again reach the chosen depth. **Fig. 4**

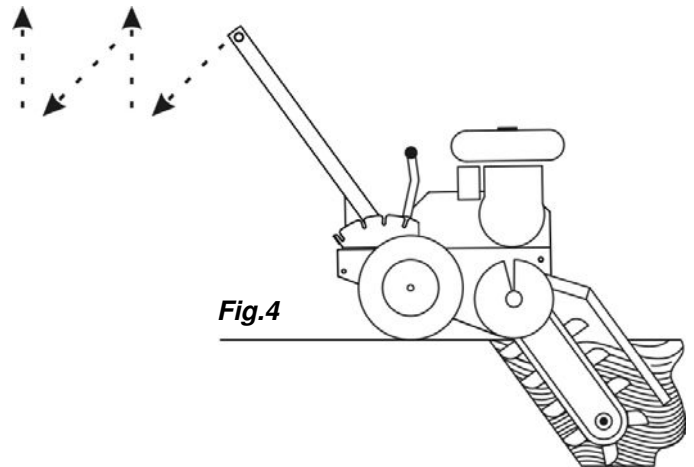

Fig.4

5. Repeat this action until you have finished the job. The wheel lock will aid you in this operation by helping to hold the trencher in position until the next motion is started.

NOTE: This is a general description on how to trench. Soil conditions and operator experience will dictate actual trenching action and speed.



OPERATING INSTRUCTIONS cont'd...



WARNING

The trencher shall be stored in a manner that prevents it from falling, rolling or tipping over.

WHEN NOT IN USE

- Store the trencher and fuel in an area where fuel vapors cannot reach sources of combustion like water heaters, electric motors, switches, furnaces, etc.
 - Always shut off the fuel valve and engine before storing or transporting.
 - Always shut off the stop switches when not in use.
 - Keep children, bystanders and animals clear of trencher at all times.
 - Secure the trencher in a manner that will not allow it fall, tip over or roll.
 - Always place the trencher on level ground and use wheel chocks to prevent the trencher from rolling when not in use.
-

