

# Operator's Manual

Dumpers

**100115012001**



Machine models	1001/1501/2001
Edition	3.0
Language	En
Item no.	1000103795



**WACKER  
NEUSON**

## Documentation

Description		Order no.
Operator's Manual		1000103795
Spare parts catalogue	1001	1000135891/1000164057
	1501	1000165936/1000135893
	2001	1000110328/1000184835

## Legend

Edition	Issued
2.0	12/2007
2.1	09/2009
3.0	01 / 2010

Copyright – 2010 Wacker Neuson Linz GmbH, Linz-Leonding  
Printed in Austria  
All rights reserved

No part of this publication may be reproduced, translated or used in any form or by any means – graphic, electronic or mechanical including photocopying, recording, taping or information storage or retrieval systems – without prior permission in writing from the manufacturer.

The cover features the machine with possible optional equipment.

Translation of original Operator's Manual



Wacker Neuson Linz GmbH  
Haidfeldstr. 37  
A-4060 Linz-Leonding

Document: BA 1001/1501/2001 En  
Order no.: 1000103795  
Edition: 3.0



---

**Table of contents**

**Introduction**

Important information on this Operator's Manual .....	1-1
Brief description .....	1-2
Regulations .....	1-2
EC declaration of conformity dumper 1001AB (serial number: AB ...)	1-3
EC declaration of conformity dumper 1501AB from serial number: AB ...	1-4
EC declaration of conformity dumper 2001 CB (serial number: CB ...)	1-5
Type labels and component numbers .....	1-6
Other signs and symbols .....	1-7

**Safety instructions**

Identification of warnings and dangers .....	2-1
Warranty .....	2-1
Designated use and exemption from liability .....	2-2
General conduct and safety instructions .....	2-3
Organisational measures .....	2-3
Selection and qualification of staff, basic responsibilities .....	2-4
Safety instructions regarding operation .....	2-5
Normal operation .....	2-5
Trailer operation .....	2-7
Safety instructions for maintenance .....	2-8
Warning of special hazards .....	2-10
Electrical energy .....	2-10
Gas, dust, steam, smoke .....	2-10
Hydraulics .....	2-11
Noise .....	2-11
Oil, grease and other chemical substances .....	2-11
Battery .....	2-11
Tyres .....	2-11

**Operation**

Description of 2001S components (overview) .....	3-4
Description of 2001 SLE components .....	3-5
1001/1501/1501S operating equipment up to serial number AB ...	3-6
1001/1501/1501S operating equipment from serial number AB ...	3-7
2001/2001SLE operating equipment .....	3-8
Putting into operation .....	3-9
Safety instructions .....	3-9
Putting the machine into operation for the first time .....	3-9
Running-in period .....	3-9
Check lists .....	3-10
Start-up checklist .....	3-10
Operation checklist .....	3-11
Parking checklist .....	3-11
Driving the dumper .....	3-12
Preheating start switch: overview .....	3-12
Accelerator pedal: overview .....	3-12
Telltapes and warning lights: overview .....	3-13
Before starting the engine .....	3-15
Starting the engine: general .....	3-15
Procedure .....	3-15
When the engine has started ... ..	3-16
Engine warm-up .....	3-16
Jump-starting the engine (supply battery) .....	3-16
Special instructions for driving on public roads .....	3-17



Moving off .....	3-17
Hydraulic brake .....	3-18
Mechanical brake .....	3-18
Hazard warning system .....	3-18
Driving on slopes .....	3-19
Specific safety instructions .....	3-19
Driving on slopes with a loaded skip .....	3-20
Driving on slopes with an empty skip .....	3-20
Driving across slopes .....	3-20
Parking the machine .....	3-21
Loading the machine .....	3-22
Seat adjustment .....	3-23
Weight adjustment .....	3-23
Horizontal adjustment .....	3-23
Backrest adjustment .....	3-23
Seat belt .....	3-24
Engine cover .....	3-25
Working with the machine .....	3-26
General safety instructions .....	3-26
High-tip skip operation (1001 + 1501H + 1501S) .....	3-27
Swivel skip operation .....	3-28
Loader unit (2001 SLE) .....	3-28
Information on working with the loader unit .....	3-30
Rollbar .....	3-30
Towing 1001/1501/1501 S/2001 .....	3-31
Opening the high-pressure circuit 1001/1501/1501 S .....	3-31
Releasing the hydraulic parking brake 1001/1501/1501 S .....	3-31
Opening the high-pressure circuit 2001 .....	3-32
Releasing the hydraulic parking brake 2001 .....	3-32
Centre pivot strut .....	3-33
Locking the control levers .....	3-33
Crane handling the machine .....	3-34
Loading and transporting the machine .....	3-35
Tying down the machine .....	3-36
Battery master switch 1001 – 1501 .....	3-36
<b>Troubleshooting</b>	
Engine trouble .....	4-1
<b>Maintenance</b>	
Introduction .....	5-1
Front skip maintenance strut 1001 .....	5-1
Maintenance strut, model 1501 .....	5-2
Maintenance strut 2001 .....	5-3
Fuel system .....	5-4
Specific safety instructions .....	5-4
Refuelling .....	5-4
Stationary fuel pumps .....	5-5
Diesel fuel specification .....	5-5
Bleeding the fuel system .....	5-5
Fuel prefilter with water separator .....	5-6
Replacing the fuel filter .....	5-7
Engine lubrication system .....	5-8
Checking the oil level .....	5-8
Filling up engine oil .....	5-9
Engine and hydraulics cooling system .....	5-10
Specific safety instructions .....	5-10
Checking/filling up coolant .....	5-11



Air filter .....	5-13
Replacing the filter .....	5-14
V-belt .....	5-15
Checking V-belt tension .....	5-15
Retightening the V-belt .....	5-16
Hydraulic system .....	5-17
Specific safety instructions .....	5-17
Checking the hydraulic oil level .....	5-18
Filling up hydraulic oil .....	5-19
Changing hydraulic oil .....	5-20
Fouling indicator for hydraulic oil filter .....	5-20
Replacing the hydraulic oil filter element .....	5-20
Important information for the use of biodegradable oil .....	5-21
Checking hydraulic pressure lines .....	5-22
Tyres .....	5-23
Inspection work .....	5-23
Wheel change .....	5-24
Electrical system .....	5-25
Specific safety instructions .....	5-25
Service and maintenance work at regular intervals .....	5-25
Instructions concerning specific components .....	5-26
Alternator .....	5-26
Battery .....	5-27
General maintenance work .....	5-28
Cleaning .....	5-28
General instructions for all areas of the machine .....	5-28
Exterior of the machine .....	5-29
Engine compartment .....	5-29
Screw connections and attachments .....	5-29
Pivots and hinges .....	5-29
Engine/machine fluids and lubricants (1001 and 1501) .....	5-30
Engine/machine fluids and lubricants (2001) .....	5-32
Maintenance plan 1001 – 1501: overview .....	5-34
Maintenance plan 2001: overview .....	5-37
Lubrication points 1001: overview .....	5-40
Lubrication points 1501: overview .....	5-41
Lubrication points 1501S: overview .....	5-42
Lubrication points 2001: overview .....	5-43
<b>Specifications (1001 – 1501)</b>	
Chassis .....	6-1
Engine .....	6-1
Travelling drive .....	6-2
Brakes .....	6-2
Steering system .....	6-2
Work hydraulics .....	6-2
Loader unit.....	6-2
Drive specifications.....	6-3
Electrical system (up to AC000101) .....	6-3
Fuse box .....	6-3
Relays .....	6-3
Electrical system (from AB150001H/150002D) .....	6-4
Fuse box .....	6-4
Relays .....	6-4



---

Tyres 1001/1501/2001 .....	6-5
Noise levels .....	6-5
Coolant compound table .....	6-5
Dimensions model 1001 .....	6-6
Dimensions model 1501 .....	6-7
Dimensions model 1501S .....	6-8
<b>Specifications (2001)</b>	
Engine .....	6-9
Travelling drive .....	6-10
Brakes .....	6-10
Steering system .....	6-10
Work hydraulics .....	6-10
Loader unit .....	6-10
Drive specifications .....	6-11
Electrical system .....	6-11
Fuse box .....	6-11
Relays .....	6-12
Tyres .....	6-13
Noise levels .....	6-13
Coolant compound table .....	6-13
Tyres .....	6-14
Noise levels .....	6-14
Coolant compound table .....	6-14
Dimensions model 2001 .....	6-15
<b>Safety instructions for operation of earth moving machines</b>	
Preliminary remark .....	7-1
Designated use .....	7-1
General .....	7-2
Danger area .....	7-3
Stability .....	7-3
Operation .....	7-4
Assembly, maintenance, repair .....	7-8
Towing and transporting .....	7-10
Monitoring .....	7-10

**Numerisch**

14 .....3-8

**A**

Abbreviations .....1-1

Air filter .....5-13

**B**

Biodegradable oil .....5-21

**C**

Check lists .....3-10

Crane-handling bracket .....3-34

**D**

Designated use and exemption from liability .....2-2

Driving on public roads .....3-17

Driving the dumper .....3-12

**F**

Fastening the seat belt .....3-24

Fluids and lubricants ..... 5-30, 5-32

**I**

Important information

On this Operator's Manual .....1-1

Instrument panel overview ..... 3-2, 3-3, 3-4, 3-5

**L**

Legal regulations .....1-2

**M**

Machine

Brief description .....1-2

Loading and transporting .....3-35

Maintenance

Air filter .....5-14

Biodegradable oil .....5-21

Checking the coolant level .....5-11

Checking the engine oil level .....5-8

Checking the hydraulic oil level .....5-18

Cleaning .....5-28

Electrical system .....5-25

Engine and hydraulics cooling system .....5-10

Engine lubrication system .....5-8

Filling in engine oil .....5-9

Filling up coolant .....5-11

Filling up hydraulic oil .....5-19

Fluids and lubricants ..... 5-30, 5-32

Fuel system .....5-4

General maintenance work .....5-28

Hydraulic pressure lines .....5-22

Hydraulic system .....5-17

Instructions concerning specific components .....5-26

Maintenance plan ..... 5-34, 5-37

Pivots and hinges .....5-29

Replacing the fuel filter .....5-7

Screw connections .....5-29

Service and maintenance work at regular intervals .....5-25

Tyres .....5-23

V-belt .....5-15

**O**

Operation .....3-1

Before starting the engine .....3-15

Control stand overview .....3-5

Description of 1001/1501 components (overview) .....3-2

Description of 1501S components (overview) .....3-3

Description of 2001S components (overview) .....3-4

Instrument panel overview .....3-2, 3-3, 3-4, 3-5

Parking the machine .....3-21

Seat belt height adjustment .....3-24

Starting the engine .....3-15

**P**

Preheating start switch .....3-12

Putting into operation .....3-2, 3-3, 3-4, 3-5

Check lists .....3-10

Putting the machine into operation for the first time .....3-9

Safety instructions .....3-9

**R**

Refuelling .....5-4

Rollbar .....3-30

Running-in period .....3-9

**S**

Safety instructions

General conduct .....2-3

Identification .....2-1

Maintenance .....2-8

Operation .....2-5

Special hazards .....2-10

Trailers and attachments .....2-7

Seat adjustment .....3-23

Backrest adjustment .....3-23

Horizontal adjustment .....3-23

Weight adjustment .....3-23

Seat belt .....3-24

Signs and symbols .....1-7

Specifications .....6-1, 6-9

Chassis .....6-1

Coolant compound table .....6-5, 6-13, 6-14

Dimensions .....6-6, 6-7, 6-8, 6-15

Electrical system .....6-3, 6-4, 6-11

Engine .....6-1, 6-9

Noise levels .....6-5, 6-13, 6-14

Starting aid .....3-16

**T**

Telltails .....3-13

Tyres .....5-23

**W**

Warranty .....2-1





# 1 Introduction

## 1.1 Important information on this Operator's Manual

Please store the Operator's Manual in the storage bin under the engine cover.

This Operator's Manual contains important information on how to work safely, correctly and economically with the machine. Therefore, it aims not only at new operators, but it also serves as a reference for experienced ones. It helps to avoid dangerous situations and reduce repair costs and downtimes. Furthermore, the reliability and the service life of the machine will be increased by following the instructions in the Operator's Manual. This is why **the Operator's Manual must always be kept at hand on the machine.**

Your own safety, as well as the safety of others, depends to a great extent on how the machine is moved and operated. Therefore, carefully read and understand this Operator's Manual prior to the first drive. This Operator's Manual will help to familiarise yourself more easily with the machine, thereby enabling you to use it more safely and efficiently.



Prior to the first drive, carefully read chapter "Safety Instructions" as well, in order to be prepared for possible dangerous situations, as it will be too late for it during operation. As a rule, keep the following in mind:

### **Careful and prudent working is the best way to avoid accidents!**

Operational safety and readiness of the machine do not only depend on your skill, but also on maintenance and servicing of the machine. This is why regular maintenance and service work is absolutely necessary. Extensive maintenance and repair work must always be carried out by an expert with appropriate training. Insist on using original spare parts when carrying out maintenance and repair work. This ensures operational safety and readiness of your machine, and maintains its value.

Your Wacker Neuson dealer will be pleased to answer any further questions regarding the machine or the Operator's Manual.

### **Abbreviations/symbols**

- This symbol stands for a list
    - Subdivision within lists or an activity. Follow the steps in the recommended sequence
  -  This symbol requires you to carry out the activity described
  -  Description of the effects or results of an activity
  - n. s. = not shown
  - "Opt" = option
- Stated whenever controls or other components of the machine are installed as an option.



## 1.2 Brief description

The model 1001/1501/2001 dumpers are self-propelled work machines.

Get informed on and follow the legal regulations of your country.

This machine is a versatile and powerful helper for moving earth, gravel and debris on construction sites and elsewhere. The main components of the machine are:

- Rollbar
- Hydraulic swivel skip or front skip
- Yanmar three cylinder diesel engine
- Sturdy steel sheet chassis

## 1.3 Regulations

### Requirements to be met by the driver

Earth moving machines may be driven and serviced only by persons who meet the following requirements:

- 18 years or older
- Physically and mentally suited for this work
- Persons have been instructed in driving and servicing the earth moving machine and have proven their qualifications to the contractor
- Persons are expected to carry out work reliably.

They have been appointed by the contractor for driving and servicing the earth moving machine.

Get informed on and follow the legal regulations of your country.



**1.4 EC declaration of conformity dumper 1001AB (serial number: AB ...)**



**EC Declaration of Conformity**

According to Machine Directive 2006/42/EC, appendix II A

**Manufacturer**

Wacker Neuson Linz GmbH  
Haidfeldstr. 37  
A-4060 Linz-Leonding

**Product**

Machine designation:	Compact dumper
Machine model:	1001
Serial no.:	_____
Output (kW):	17 kW
Measured sound power level:	100.6 dB (A)
Guaranteed sound power level:	101 dB (A)

**Conformity assessment procedure**

Notified body according to Directive 2006/42/EC, appendix XI:  
Fachausschüsse Bau und Tiefbau  
Prüf- und Zertifizierungsstelle im BG-PRÜFZERT  
Landsberger Str. 309  
D-80687 Munich  
Distinguishing EU number 0036


Notified body according to Directive 2000/14/EC, appendix VI:  
TÜV SÜD Industrie Service GmbH  
Westendstr. 199  
D-80686 Munich

**Directives and standards**

We hereby declare that this product corresponds to the relevant regulations and requirements of the following Directives and standards:

2006/42/EC (old 98/37 EC), 2004/108/EC (old 89/336/EEC), 2002/44/EC, 2005/88/EC, 2000/14/EC;  
DIN EN ISO 12100-1 and 2, DIN EN 474-1 and 6, DIN EN 14121,  
DIN EN 3471, DIN EN 13510, EN ISO 3744, EN ISO 3746, DIN EN ISO 3449

Leonding, \_\_\_\_\_  
Place, date

  
Thomas Köck,  
Responsible for documentation

  
Josef Erlinger,  
Managing director



## 1.5 EC declaration of conformity dumper 1501AB from serial number: AB ...

WACKER  
NEUSON**EC Declaration of Conformity**

According to Machine Directive 2006/42/EC, appendix II A

**Manufacturer**

Wacker Neuson Linz GmbH  
 Haidfeldstr. 37  
 A-4060 Linz-Leonding

**Product**

Machine designation:	Compact dumper
Machine model:	1501
Serial no.:	_____
Output (kW):	17 kW
Measured sound power level:	101 dB (A)
Guaranteed sound power level:	101 dB (A)

**Conformity assessment procedure**

Notified body according to Directive 2006/42/EC, appendix XI:  
 Fachausschüsse Bau und Tiefbau  
 Prüf- und Zertifizierungsstelle im BG-PRÜFZERT  
 Landsberger Str. 309  
 D-80687 Munich  
 Distinguishing EU number 0036

Notified body according to Directive 2000/14/EC, appendix VI:  
 TÜV SÜD Industrie Service GmbH  
 Westendstr. 199  
 D-80686 Munich

**Directives and standards**

We hereby declare that this product corresponds to the relevant regulations and requirements of the following Directives and standards:

2006/42/EC (old 98/37 EC), 2004/108/EC (old 89/336/EEC), 2002/44/EC, 2005/88/EC, 2000/14/EC;  
 DIN EN ISO 12100-1 and 2, DIN EN 474-1 and 6, DIN EN 14121,  
 DIN EN 3471, DIN EN 13510, EN ISO 3744, EN ISO 3746, DIN EN ISO 3449

Leonding, \_\_\_\_\_  
 Place, date

Thomas Köck,  
 Responsible for documentation

Josef Erlinger,  
 Managing director



**1.6 EC declaration of conformity dumper 2001 CB (serial number: CB ...)**



**WACKER  
NEUSON**

**EC Declaration of Conformity**

According to Machine Directive 2006/42/EC, appendix II A

**Manufacturer**

Wacker Neuson Linz GmbH  
Haidfeldstr. 37  
A-4060 Linz-Leonding

**Product**

Machine designation:	Compact dumper
Machine model:	2001
Serial no.:	_____
Output (kW):	22.5 kW
Measured sound power level:	101.1 dB (A)
Guaranteed sound power level:	101 dB (A)

**Conformity assessment procedure**

Notified body according to Directive 2006/42/EC, appendix XI:  
Fachausschüsse Bau und Tiefbau  
Prüf- und Zertifizierungsstelle im BG-PRÜFZERT  
Landsberger Str. 309  
D-80687 Munich  
Distinguishing EU number 0036

Notified body according to Directive 2000/14/EC, appendix VI:  
TÜV SÜD Industrie Service GmbH  
Westendstr. 199  
D-80686 Munich

**Directives and standards**

We hereby declare that this product corresponds to the relevant regulations and requirements of the following Directives and standards:

2006/42/EC (old 98/37 EC), 2004/108/EC (old 89/336/EEC), 2002/44/EC, 2005/88/EC, 2000/14/EC;  
DIN EN ISO 12100-1 and 2, DIN EN 474-1 and 6, DIN EN 14121,  
DIN EN 3471, DIN EN 13510, EN ISO 3744, EN ISO 3746, DIN EN ISO 3449

Leonding, \_\_\_\_\_  
Place, date

Thomas Köck,  
Responsible for documentation

Josef Erlinger,  
Managing director

## 1.7 Type labels and component numbers

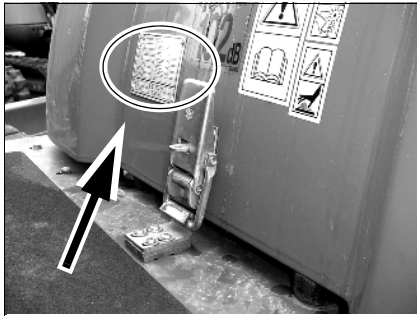


Fig. 1: Type label location

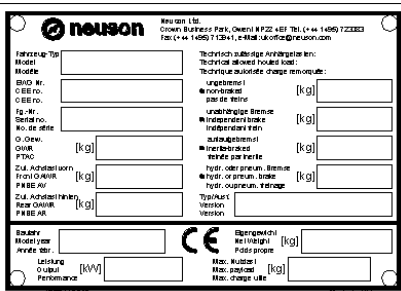


Fig. 2: Type label

### Serial number

The serial number is stamped on the machine chassis. It is also located on the type label.

The type label is located at the rear right of the control stand.

Type label information

Example: 1001

Model: 1001  
 Year: -----  
 PIN: (serial number) AB1001 ...  
 Power: -----  
 Mass: -----  
 Load: -----

Other information – see [chapter 6 Specifications \(1001 – 1501\)](#) on page 6-1

### Engine number

The type label (arrow) is located on the valve cover of the engine.

Example: Yanmar 46557

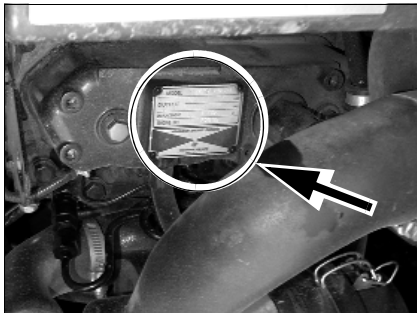


Fig. 3: Yanmar diesel engine number

### Hydraulic pump number

The type label (arrow) is located on the hydraulic pump housing

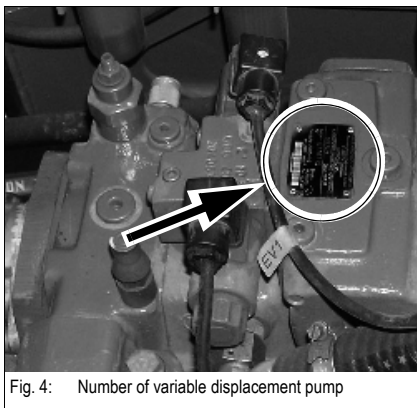


Fig. 4: Number of variable displacement pump

### Rollbar number

The type label is located on the left on the rollbar



Fig. 5: Rollbar type label

## 1.8 Other signs and symbols

The following states signs and symbols which are not unequivocally comprehensible. They do not contain explanatory text and are not explained in the following chapters.

Short model designations

☞ 1501 swivel skip = 1501S

☞ 1501 high-tip skip = 1501H

### Meaning

Raise the machine or machine parts only by means of these eyelets.

### Location

The label is affixed in different positions on the machine next to the eye hooks.



Fig. 6: Eye hook

### Meaning

Machine runs with diesel fuel. Fill in diesel fuel only!

### Location

On the fuel tank



Fig. 7: Fuel tank

### Meaning

Tank contains hydraulic oil

### Location

On the hydraulic oil tank

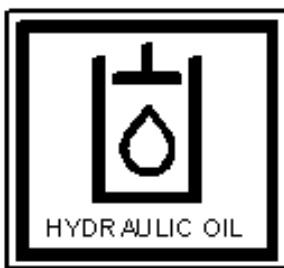


Fig. 8: Hydraulic oil tank

### Meaning

Shows how the skip can be dumped out.

### Location

On the engine cover



Fig. 9: Dumping out the skip

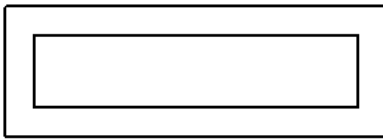


Fig. 10: Serial number

**Meaning**

This label includes the serial number of the machine

**Location**

At the front right of the chassis



Fig. 11: Sound power level

**Meaning**

Value of sound power level according to the 2000/14/EC standard.

**Location**

On the engine cover



Fig. 12: Lap belt

**Meaning**

Always fasten the lap belt if the rollbar is raised!

Using the machine with the rollbar folded down is prohibited!

**Location**

On the engine cover

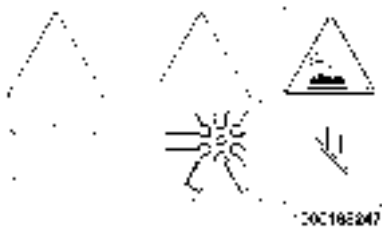


Fig. 13: Rotating and hot parts

**Meaning**

Caution – rotating or hot parts! Read the Operator's Manual.

**Location**

On the engine cover

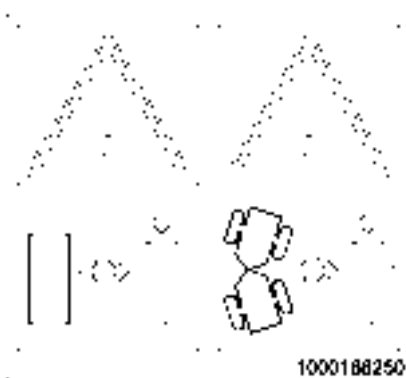


Fig. 14: Distance to machine

**Meaning**

Indicates that persons other than the driver must keep a safe distance from the machine during operation!

**Location**

On the skip





Fig. 15: Towing

**Meaning**

Machine must be towed away only by trained staff. Follow the instructions in the Operator's Manual!

**Location**

On the engine cover

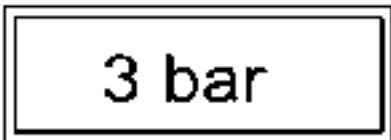


Fig. 16: Tyre pressure

**Meaning**

This label states the tyre pressure.

**Position (1501S-H, 1001)**

On the mudguards and the skip



Fig. 17: Parking brake

**Meaning**

Parking brake

**Position (1501H-S, 1001)**

Control stand



Fig. 18: Raising and lowering the skip

**Meaning**

Information on raising/lowering the skip

**Position (1501H, 1001)**

On the engine cover



Fig. 19: Angle of inclination

**Meaning**

This label indicates the maximum authorised angle of inclination for driving on slopes, whatever the position of the machine.

**Position (1001)**

Skip



Fig. 20: Skip swivel

**Meaning**

Information on swivelling the skip to the left/right

**Position (1501S, 2001)**

On the engine cover

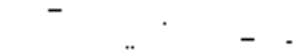


Fig. 21: Angle of inclination

**Meaning**

This label indicates the maximum authorised angle of inclination for driving on slopes, whatever the position of the machine.

**Position (1501S)**

Skip



Fig. 22: Tyre pressure

**Meaning**

This label states the tyre pressure.

**Position (2001)**

2x on mudguards

2x on skip

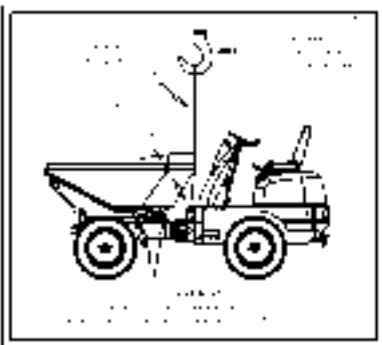


Fig. 23: Loading the dumper

**Meaning**

Loading the dumper

**Position (2001)**

At the rear right on the chassis

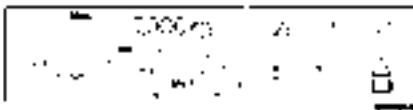


Fig. 24: Angle of inclination

**Meaning**

This label indicates the maximum authorised angle of inclination for driving on slopes, whatever the position of the machine.

**Position (2001)**

Skip



Fig. 25: Maintenance strut

**Meaning**

Maintenance strut

**Location**

On the front chassis (1001, 1501) and on the swivelling console (2001)

## 2 Safety instructions


### 2.1 Identification of warnings and dangers

Important indications regarding the safety of the staff and the machine are identified in this Operator's Manual with the following terms and symbols:



#### **Danger!**

Failure to observe the instructions identified by this symbol can result in personal injury or death for the operator or other persons.

 *Measures for avoiding danger*

---



#### **Caution!**

Failure to observe the instructions identified by this symbol can result in damage to the machine.

 *Measures for avoiding danger for the machine*

---



#### **Notice!**

This symbol identifies instructions for a more efficient and economical use of the machine.

---



#### **Environment!**

Failure to observe the instructions identified by this symbol can result in damage to the environment. The environment is in danger if environmentally hazardous material (e.g. waste oil) is not subject to proper use or disposal.

---

### 2.2 Warranty

Warranty claims can be brought forward to your Wacker Neuson dealer only. Furthermore, the instructions in this Operator's Manual must be observed.



### 2.3 Designated use and exemption from liability

- The machine is intended for:
  - Moving earth, gravel, coarse gravel or ballast and rubble
  - Every other application is regarded as not designated for the use of the machine. Wacker Neuson will not be liable for damage resulting from use other than mentioned above. The user alone will bear the risk. Designated use also includes observing the instructions set forth in the Operator's Manual and observing the maintenance and service conditions.
- The safety of the machine can be negatively affected by carrying out machine modifications without proper authority and by using spare parts, equipment, attachments and optional equipment which have not been checked and released by Wacker Neuson GmbH. Wacker Neuson GmbH will not be liable for damage resulting from this
- Wacker Neuson GmbH shall not be liable for personal injury and/or damage to property caused by failure to observe the safety instructions and the Operator's Manual, and by the negligence of the duty to exercise due care when:
  - handling
  - operating
  - servicing and carrying out maintenance work and
  - repairing the machine. This is also applicable in those cases in which special attention has not been drawn to the duty to exercise due care, in the safety instructions, the Operator's Manuals and maintenance manuals (machine/engine).
  - Read and understand the Operator's Manual before starting up, servicing or repairing the machine. Observe the safety instructions!
- When driving on public roads, follow the legal regulations of your country and equip the machine in compliance with these regulations. If the machine is not equipped with lights, drive on construction sites only, and only in conditions of sufficient visibility.



## 2.4 General conduct and safety instructions

### Organisational measures

- The machine has been designed and built in accordance with state-of-the-art standards and the recognised safety regulations. Nevertheless, its use can constitute a risk to life and limb of the user or of third parties, or cause damage to the machine and to other material property
- The machine must only be used in technically perfect condition in accordance with its designated use and the instructions set forth in the Operator's Manual, and only by safety-conscious persons who are fully aware of the risks involved in operating the machine. Any functional disorders, especially those affecting the safety of the machine, must therefore be rectified immediately!  
**Basic rule:**  
Before starting up the machine, inspect the machine for safety in work and road operation!
- Careful and prudent working is the best way to avoid accidents!
- The Operator's Manual must always be at hand on the machine and must therefore be stored in the tool kit.  
Immediately complete or replace an incomplete or illegible Operator's Manual.
- In addition to the Operator's Manual, observe and instruct the operator in all other generally applicable legal and other mandatory regulations relevant to accident prevention and environmental protection.  
These compulsory regulations may also deal with handling hazardous substances, issuing and/or wearing personal protective equipment, or traffic regulations
- With regard to specific operational features, e.g. those relevant to job organisation, work sequences or the persons entrusted with the work, supplement the Operator's Manual by corresponding instructions, including those relevant to supervising and reporting duties
- Persons entrusted with work on the machine must have read and understood the Operator's Manual and in particular, chapter "Safety Instructions" before beginning work. This applies especially to persons working only occasionally on the machine, e.g. set-up or maintenance
- The user/owner must check – at least from time to time – whether the persons entrusted with operation or maintenance of the machine are working in compliance with the Operator's Manual and are aware of risks and safety factors
- The user/owner commits himself to operate and keep the machine in perfect condition, and, if necessary or required by law, to require the operating or servicing persons to wear protective clothing etc.
- In the event of safety-relevant modifications or changes on the machine or of its behaviour, stop the machine immediately and report the malfunction to the competent authority/person. Safety-relevant damage or malfunctions of the machine must be rectified immediately
- Never make any modifications, additions or conversions to the machine and its super-structures, as well as to the attachments, which might affect safety without the approval of Wacker Neuson! This also applies to the installation and the adjustment of safety devices and valves, as well as to welding work on load-bearing elements
- Spare parts must comply with the technical requirements specified by Wacker Neuson. Original spare parts can be relied to do so.
- Replace hydraulic hoses within stipulated and appropriate intervals even if no safety-relevant defects have been detected.



- Before working on or with the machine, remove jewellery, such as rings, wristwatches, bracelets etc., and tie back long hair and do not wear loose-fitting garments, such as unbuttoned or unzipped jackets, ties or scarves.  
Injury can result from being caught up in the machinery or from rings catching on moving parts!
- Keep the machine clean. This reduces
  - Fire hazard, e.g. due to oil-soaked rags lying around
  - Danger of injury, e.g. due to dirt or debris on the footholds, and
  - Danger of accidents e.g. due to dirt pile-up on the drive pedals
- Observe all safety, warning and information signs and labels on the machine
- Adhere to prescribed intervals or those specified in the Operator's Manual for routine checks/inspections and maintenance work!
- For service, inspection, maintenance or repair work, tools and workshop equipment adapted to the task on hand are absolutely indispensable

### Selection and qualification of staff, basic responsibilities

- Any work on or with the machine must be carried out by reliable staff only. Do not let unauthorised persons drive or work with the machine! Observe statutory minimum age limits!
- Employ only trained or instructed staff on the machine, and clearly and unequivocally define the individual responsibilities of the staff for operation, set-up, maintenance and repair!
- Define the machine operator's responsibilities – also with regard to observing traffic regulations. Give the operator the authority to refuse instructions by third parties that are contrary to safety
- Do not allow persons to be trained or instructed or persons taking part in a general training course to work on or with the machine without being permanently supervised by an experienced person!
- Work on the electrical system and equipment, on the undercarriage and the steering and brake systems may be carried out only by skilled staff which has been specially trained for such work.  
Work on the hydraulic system of the machine must be carried out only by staff with special knowledge and experience in hydraulic equipment!
- Seal off the danger area should it not be possible to keep a safe distance.  
Stop work if persons do not leave the danger area in spite of warning! Keep out of the danger area!

#### **Danger area:**

The danger area is the area in which persons are in danger due to the movements of the

- machine
- work equipment
- additional equipment or
- material
- This also includes the area affected by falling material, equipment or by parts which are thrown out.  
The danger area must be extended by 0.5 m in the immediate vicinity of
- buildings
- scaffolds or
- other elements of construction



## **2.5 Safety instructions regarding operation**

### **Normal operation**

- Avoid any operational mode that might be prejudicial to safety!
- Before beginning work, familiarise yourself with the surroundings and circumstances of the work site. These are e.g. obstacles in the working and travelling area, the soil bearing capacity and any necessary barriers separating the work site from public roads
- Take the necessary precautions to make sure the machine is used only when in a safe and reliable state!  
Operate the machine only if all protective and safety-oriented devices, e.g. removable safety-devices, soundproofing elements and exhausters etc., are in place and fully functional!
- Check the machine at least once a day/per work shift for visible damage and defects. Report any changes (incl. changes in the machine's working behaviour) to the competent organisation/person immediately! If necessary, stop the machine immediately and lock it!
- In the event of malfunctions, stop the machine immediately and lock it! Have any defects rectified immediately!
- Start and operate the machine from the seat only!
- Carry out start-up and shut-down procedures in accordance with the Operator's Manual, and observe the telltales!
- Before putting the machine into operation (start-up/moving), make sure no-one is at risk by putting the machine into operation!
- Before driving the machine, and also after interrupting work, check whether the service brake, the parking brake (the drive must be switched off if the parking brake is applied!) and the signalling and the light systems are functional!
- When driving on public roads, ways and places, observe the local traffic regulations in force and, if necessary, make sure beforehand that the machine is in a condition perfectly compatible with these regulations!
- Always switch on the lights in conditions of poor visibility and after dark.
- Do not carry any other persons apart from the driver!
- When crossing underpasses, bridges and tunnels, or when passing under overhead lines always make sure there is enough clearance!
- Always keep at a safe distance from the edges of building pits and slopes!
- When working in buildings or in enclosed areas, look out for:
  - Height of the ceiling/clearances
  - Width of entrances
  - Maximum load of ceilings and floors
  - Sufficient room ventilation – danger of poisoning! (exhaust)



- Avoid any operation that might be a risk to machine stability!
- On sloping terrain always adapt your drive speed to the prevailing ground conditions! Never change to lower gear on a slope but always before reaching it!
- Before leaving the seat always secure the machine against unintentional movement and unauthorised use!
- Before starting work check whether
  - all safety devices are properly installed and functional.
  - dirt has been removed from all footholds.
- Before moving the machine or before taking up work:
  - Make sure visibility is sufficient!
  - Adjust your correct seat position, never adjust the seat when driving or working!
  - Always fasten the seat belt if the rollbar is raised!
  - Inspect the immediate area (children)!
  - In the work area the operator is responsible for third parties!
- Caution when handling fuel – increased danger of fire!
  - Make sure fuel does not come into contact with hot parts!  
Do not smoke during refuelling, and avoid fire and sparks! Stop the engine during refuelling and do not smoke!
- Never get on or off a moving machine! Never jump off the machine!
- Should it be too dark for carrying out work safely, provide additional lighting of the work area
- Installed work lights must not be switched on for travel on public roads. They can be switched on in work operation if users of public roads are not dazzled.
- Adjust the drive speed to your abilities and the circumstances.
- Always adapt your drive speed to the road and ground conditions, and to the visibility conditions. Ask someone to guide you in case of difficult passages or obstacles. Always avoid tipping over the dumper by driving appropriately and slowly as required. This applies in particular to rough terrain, the edges of trenches, curves and emergency braking. Use only the low speed range when driving off-road (turtle telltale on the instrument panel).
- Proceed with extreme care when working on slopes. The dumper can be driven on firm ground in all positions on slopes up to 25 % steep. Drive on slopes that are less steep if you expect the wheels on one side to sink in. When driving on slopes steeper than 25 %, drive the loaded dumper only with the skip facing uphill, i.e. drive downhill reversing. When driving downhill with an empty skip on slopes steeper than 25 %, the skip must face downhill.
- Make sure the engine cover is closed and locked before starting the dumper.
- When driving downhill with a full skip, drive slowly and reduce engine speed by slowly reducing the pressure on the accelerator pedal. The dumper brakes hydraulically at idling speed of the diesel engine. The centre of gravity of the payload is shifted to the front on slopes. Reverse downhill if you are not sure.
- Apply the parking brake when parking the machine. If possible, do not park the dumper on slopes. If this cannot be avoided, use wheel chocks, etc. Lower the skip before leaving the dumper. Apply the parking brake only in an emergency when driving the machine.
- Keep the base plate of the skip in a clean condition so that the material is easily dumped out of the skip. Load only material that can be easily dumped out. Dump out sticky or frozen material only to the front and with the dumper in straight-ahead position on level ground. As you raise the skip, watch whether the material is dumped out before fully raising the skip. Failure to watch whether the material is dumped out correctly can cause the dumper to **tip over**.





- Never drive too close to the edges of pits, precipices, etc., since the pressure of the wheels on the ground can cause the edge to give way. If edges are secured sufficiently and a barrier prevents the ground from giving way, you may drive closer to edges of pits, precipices, etc.
- Never dump material into trenches in which there are persons. If the driver cannot see into the trench, he must be instructed by a person who can see into the trench.
- Always make sure the brakes are in a perfect condition.

### **Trailer operation**

In spite of being equipped with towing gear, the dumper is not a tractor and may not be used as such in difficult terrain. If the dumper is used on construction sites for towing trailers, weight down the skip with 25 % of the payload. However, the towed equipment including the weight in the skip may not exceed the dumper's payload. Secure the towing pin of the towing gear with a split pin!



### 2.6 Safety instructions for maintenance

- Avoid any operational mode that might be prejudicial to safety!
- Observe the adjustment, maintenance and inspection activities and intervals set forth in the Operator's Manual, including information on the replacement of parts/partial equipment!  
These activities must be carried out by technical staff only
- The machine may not be serviced, repaired or test-driven by unauthorised staff
- Brief the staff/the driver before beginning special operations and maintenance work!  
Appoint a person to supervise the activities!
- In any work concerning the operation, conversion or adjustment of the machine and its safety-oriented devices, or any work related to maintenance, inspection and repair, observe the start-up and shut-down procedures set forth in the Operator's Manual, and the information on maintenance work
- If required, secure the maintenance area appropriately!
- Prior to carrying out service, maintenance and repair work, attach a warning label, such as "Repair work – do not start machine!", to the ignition lock or to the control elements. Remove the ignition key!
- Carry out service, maintenance and repair work only if the
  - machine is positioned on firm and level ground,
  - the forwards-reverse lever is in neutral,
  - the parking brake is applied,
  - the skip is lowered, or if the dumped-out skip is secured with the maintenance strut,
  - the engine is at a standstill,
  - ignition key is removed and
  - the machine has been secured against unintentional movement.
- Should maintenance or repair be inevitable with the engine running:
  - Observe the specific safety instructions in the work manual.
  - Keep a safe distance from all rotating and moving parts, e.g. fan blades, V-belt drives, PTO shaft drives, fans etc.
- Prior to carrying out assembly work on the machine, make sure no movable parts will roll away or start moving.
- To avoid the risk of accidents, parts and large assemblies being moved for replacement purposes must be carefully attached and secured to lifting gear.  
Use only suitable lifting gear and suspension systems in a technically perfect state with adequate load-bearing capacity!  
Stay clear of suspended loads!



- Always use specially designed or otherwise safety-oriented ladders and working platforms to carry out overhead assembly work.  
Wear a safety harness when carrying out maintenance work at greater heights!  
Remove dirt, snow and ice from all handles and footholds!
- Clean the machine, especially connections and threaded unions, of any traces of oil, fuel or preservatives before carrying out maintenance/repair work!  
Do not use aggressive detergents!  
Use lint-free cleaning rags!
- Before cleaning the machine with water, steam jet (high-pressure cleaner) or detergents, cover or tape up all openings which – for safety and functional reasons – must be protected against water, steam or detergent penetration. Special care must be taken with the electrical system
- After cleaning, remove all covers and tapes applied for that purpose!
- After cleaning, examine all fuel, lubricant and hydraulic oil lines for leaks, chafe marks and damage!  
Rectify all defects without delay!
- Always tighten any screw connections that have been loosened during maintenance and repair!
- Any safety devices removed for set-up, maintenance or repair purposes must be refitted and checked immediately upon completion of the maintenance and repair work.
- Make sure all consumables and replaced parts are disposed of safely and with minimum environmental impact!
- Before taking up work on machine parts dangerous for life and limb (bruising, cutting), always ensure safe blocking/support of these areas!
- Carry out maintenance and repair work beneath a raised machine, work equipment/ attachments or additional equipment only if a safe and secure support has been provided for (the sole use of hydraulic rams, jacks etc. does not sufficiently secure raised machines or equipment/attachments)!
- Avoid contact with hot parts, such as the engine block or the exhaust system during the operation of the machine and for some time afterwards – danger of burns!
- Retainer pins can fly out or splinter when struck with force – danger of personal injury!
- Do not use starting fuel! This especially applies to those cases in which a heater plug (intake-air preheating) is used at the same time – danger of explosions!
- Apply special care when working on the fuel system – increased danger of fire!



## 2.7 Warning of special hazards

### Electrical energy

- Use only original fuses with the specified current rating!  
Switch off the machine immediately and rectify the malfunction if trouble occurs in the electrical system!
- When working with the machine, maintain a safe distance from overhead electric lines! If work must be carried out close to overhead lines, the equipment/attachments must be kept well away from them. Caution, danger! Get informed on the prescribed safety distances!
- If your machine comes into contact with a live wire
  - Do not leave the machine
  - Drive the machine out of the danger area
  - Warn others against approaching and touching the machine
  - Have the live wire de-energised
  - Do not leave the machine until the line that has been touched or damaged has been safely de-energised!
- Work on the electrical system may only be carried out by a technician with appropriate training, in accordance with the applicable electrical engineering rules
- Inspect and check the electric equipment of the machine at regular intervals. Defects such as loose connections or scorched cables must be rectified immediately
- Observe the operating voltage of the machine/attachments!
- Always remove the earthing strap from the battery when working on the electrical system or when carrying out welding work!
- Starting with a battery jump cable can be dangerous if carried out improperly. Observe the safety instructions regarding the battery!

### Gas, dust, steam, smoke

- Operate the machine only on adequately ventilated premises! Before starting internal combustion engines or operating fuel-operated heating systems on enclosed premises, make sure there is sufficient ventilation!  
Observe the regulations in force at the respective site!
- Carry out welding, flame-cutting and grinding work on the machine only if this has been expressly authorised. There can be a risk of explosion and fire, for example!
- Before carrying out welding, flame-cutting and grinding work, clean the machine and its surroundings from dust and other inflammable substances, and make sure the premises are adequately ventilated – danger of explosions!



### Hydraulics

- Work on the hydraulic equipment of the machine must be carried out only by persons having specific technical knowledge and experience in hydraulic systems!
- Check all lines, hoses and screw connections regularly for leaks and obvious damage! Repair any damage and leaks immediately! Splashed oil can cause injury and fire.
- In accordance with the Operator's Manual/instructions for the respective assembly, release the pressure in all system sections and pressure lines (hydraulic system) to be opened before carrying out any implementing/repair work!
- Hydraulic and compressed-air lines must be laid and fitted properly. Make sure no connections are interchanged. The fittings, lengths and quality of the hoses must comply with the technical requirements

### Noise

- During operation all sound baffles must be closed.
- Wear ear protectors if necessary!

### Oil, grease and other chemical substances

- When handling oil, grease and other chemical substances (e.g. battery electrolyte – sulphuric acid), observe the product-related safety regulations (safety data sheet)!
- Be careful when handling hot consumables – risk of burning or scalding!

### Battery

- When handling the battery observe the specific safety instructions and regulations relevant to accident prevention. Batteries contain sulphuric acid – caustic!
- Especially when charging batteries, as well as during normal operation of batteries, an oxyhydrogen mixture is formed in the battery cells – danger of explosion!
- In case of a frozen battery or of an insufficient electrolyte level, do not try start-up with a battery jump cable. The battery can burst or explode
- ☞ Dispose of the battery immediately!

### Tyres

- Repair work on the tyres must be carried out by technical staff or by an authorised workshop only!
- Defective tyres reduce the machine's operational safety. Therefore carry out regular checks of the tyres for
  - Cracks, cuts or other damage
- Check the tyre pressure at regular intervals.



### 3 Operation

This chapter describes the controls, and contains information on the function and handling of the telltales and controls on the control stand.

The pages stated in the table refer to the description of the controls.

A combination of digits, or a combination of digits and letters (e.g. 40/18 or 40/A) used for identifying the control elements, means:

fig. no. 40/control element no. 18 or position **A** in fig. no. 40

Figures carry no numbers if they are placed to the left of the text.

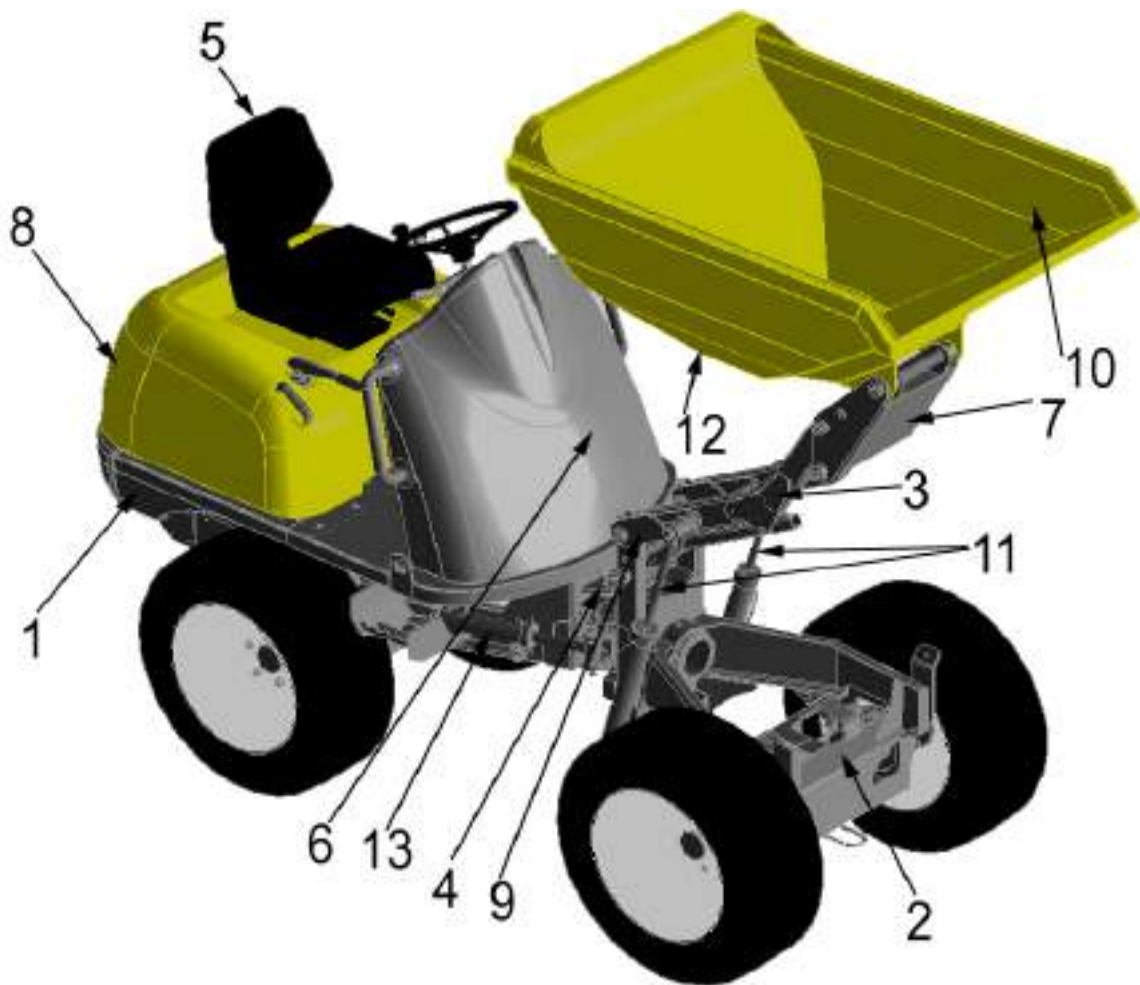
The symbols used in the description have the following meanings:

- This symbol stands for a list
  - Subdivision within lists or an activity. Follow the steps in the recommended sequence
- ☞ *This symbol requires you to carry out the activity described*
  - ➡ Description of the effects or results of an activity

n. s. = not shown

Opt = option

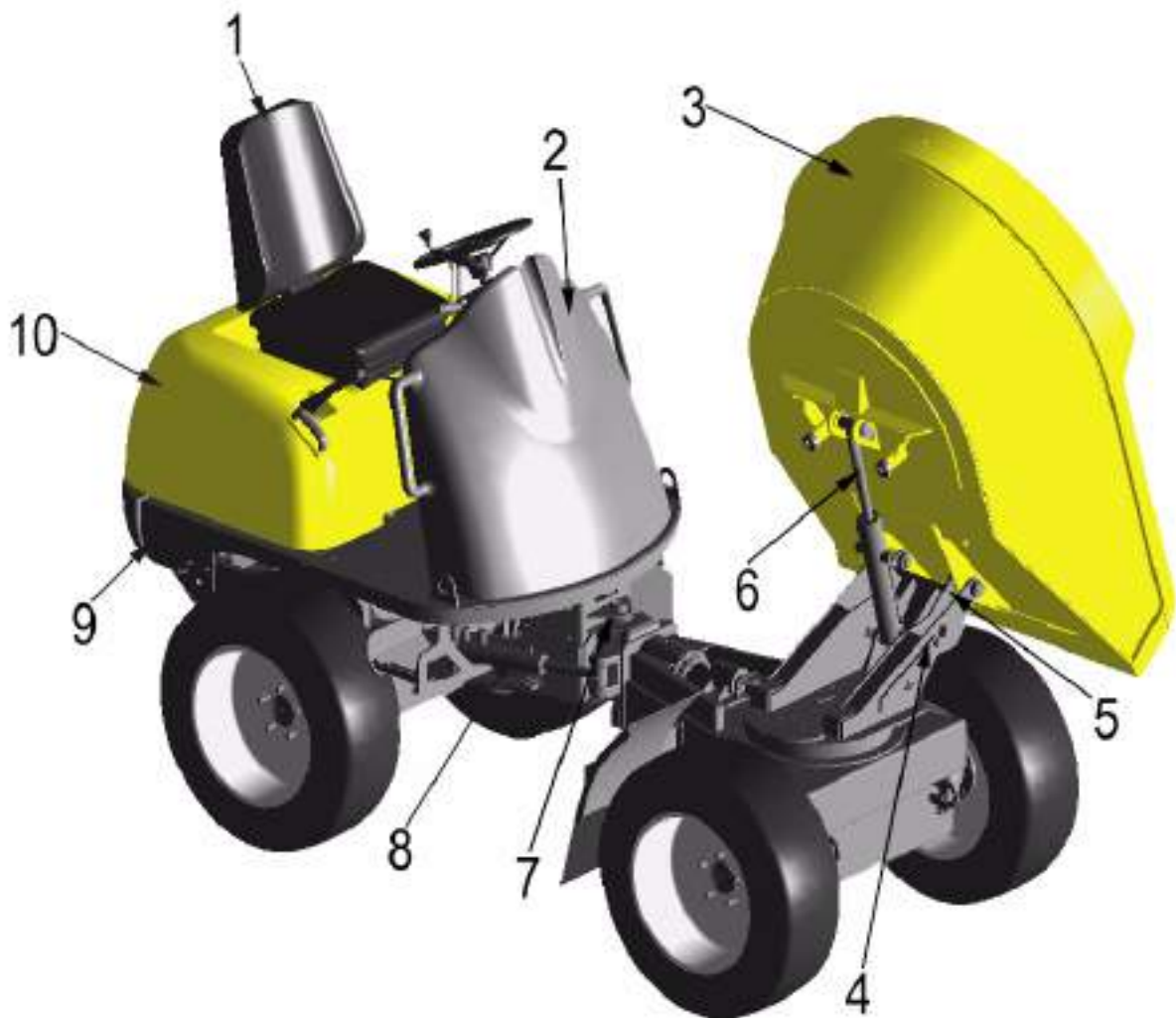
Stated whenever controls or other components of the machine are installed as an option.



### Description of 1001/1501 components (overview)

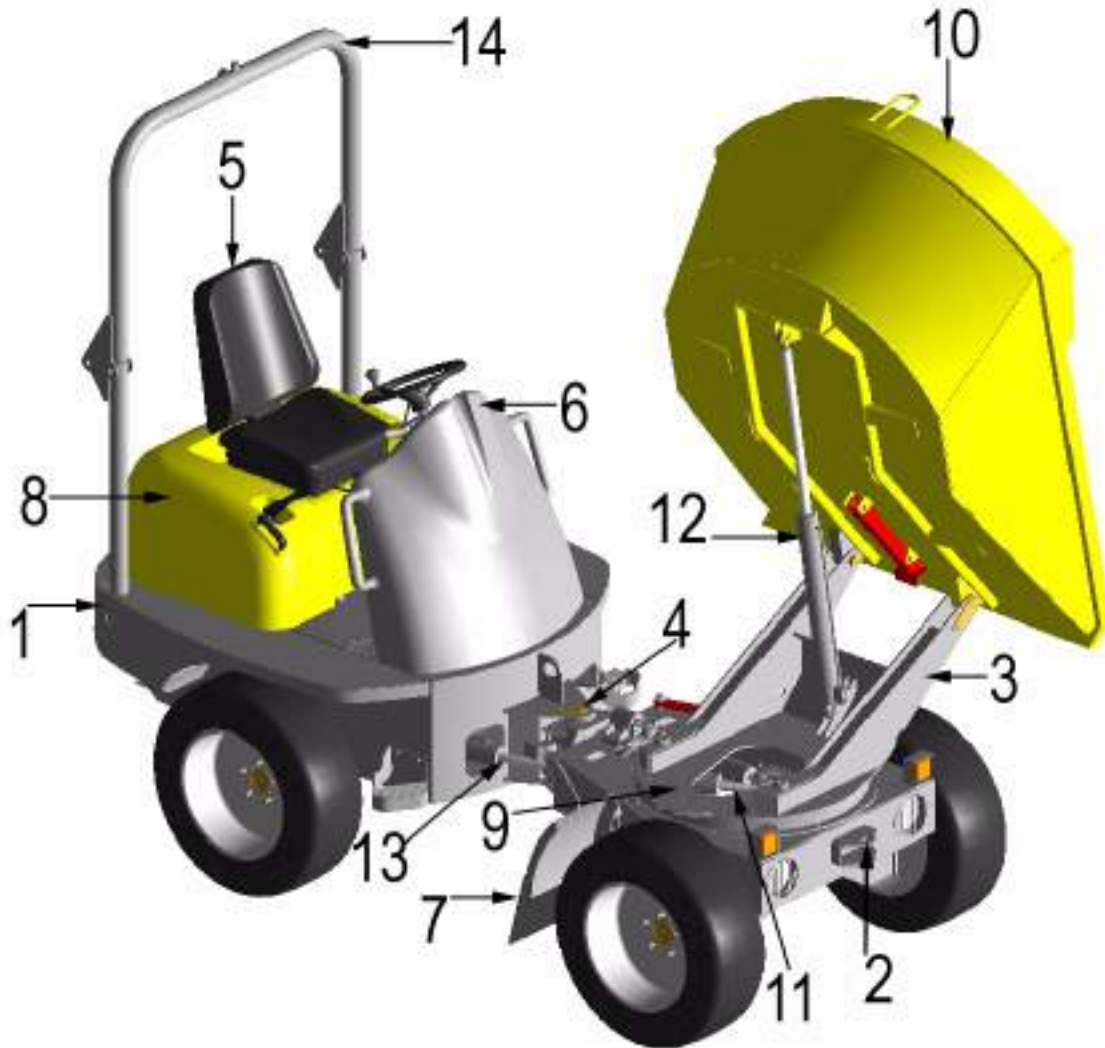
Pos.	Description
1	Rear chassis
2	Front chassis
3	Loader unit
4	Articulated joint
5	Seat
6	Control stand
7	Tilt console
8	Engine cover
9	Parallel lift
10	Skip
11	Lift ram
12	Tilt ram (not shown)
13	Steering ram





### Description of 1501S components (overview)

Pos.	Description
1	Seat
2	Control stand
3	Skip
4	Swivel centring
5	Swivelling console
6	Tilt ram
7	Articulated joint
8	Steering ram
9	Rear chassis
10	Engine cover



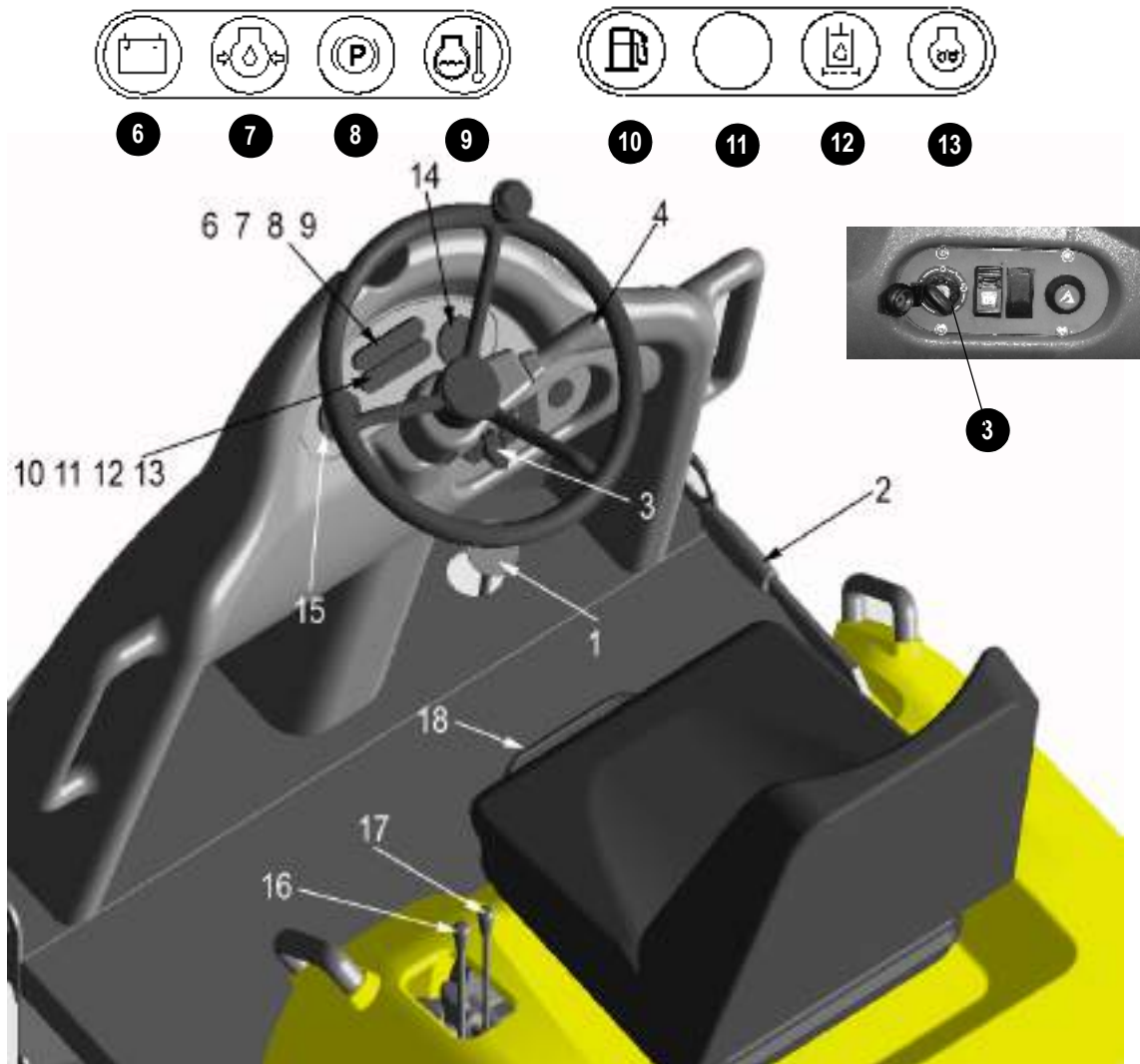
### 3.1 Description of 2001S components (overview)

Pos.	Description
1	Rear chassis
2	Front chassis
3	Swivelling console
4	Articulated joint
5	Seat
6	Control stand
7	Mudguard
8	Engine cover
9	Swivel centring
10	Skip
11	Offset ram
12	Tilt ram
13	Steering ram
14	Rollbar



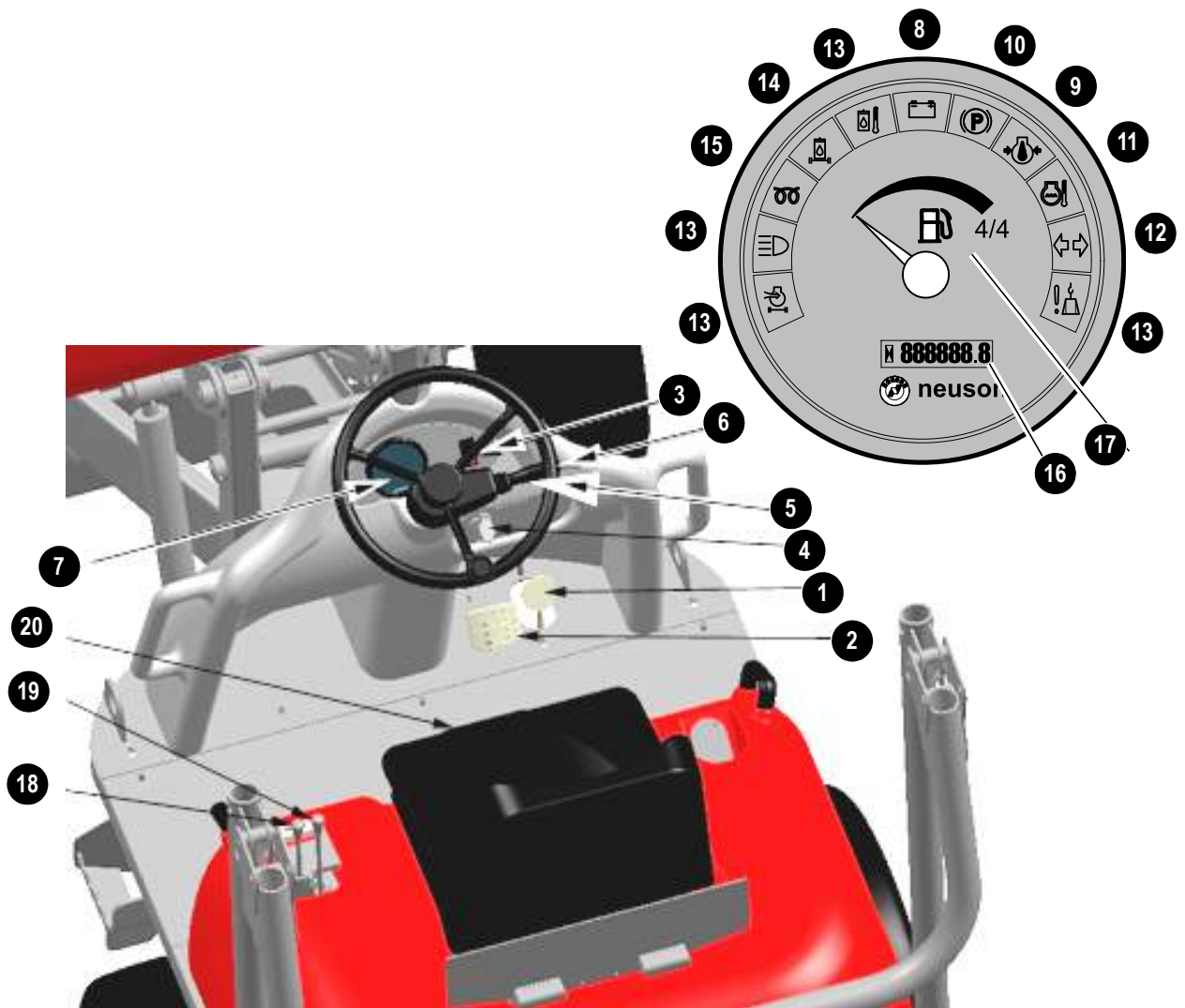
### 3.2 Description of 2001 SLE components

Pos.	Description
1	Lift frame
2	Lift ram
3	Bucket ram
4	Bucket
5	Fastening mount
6	Articulation (large)
7	Articulation (small)



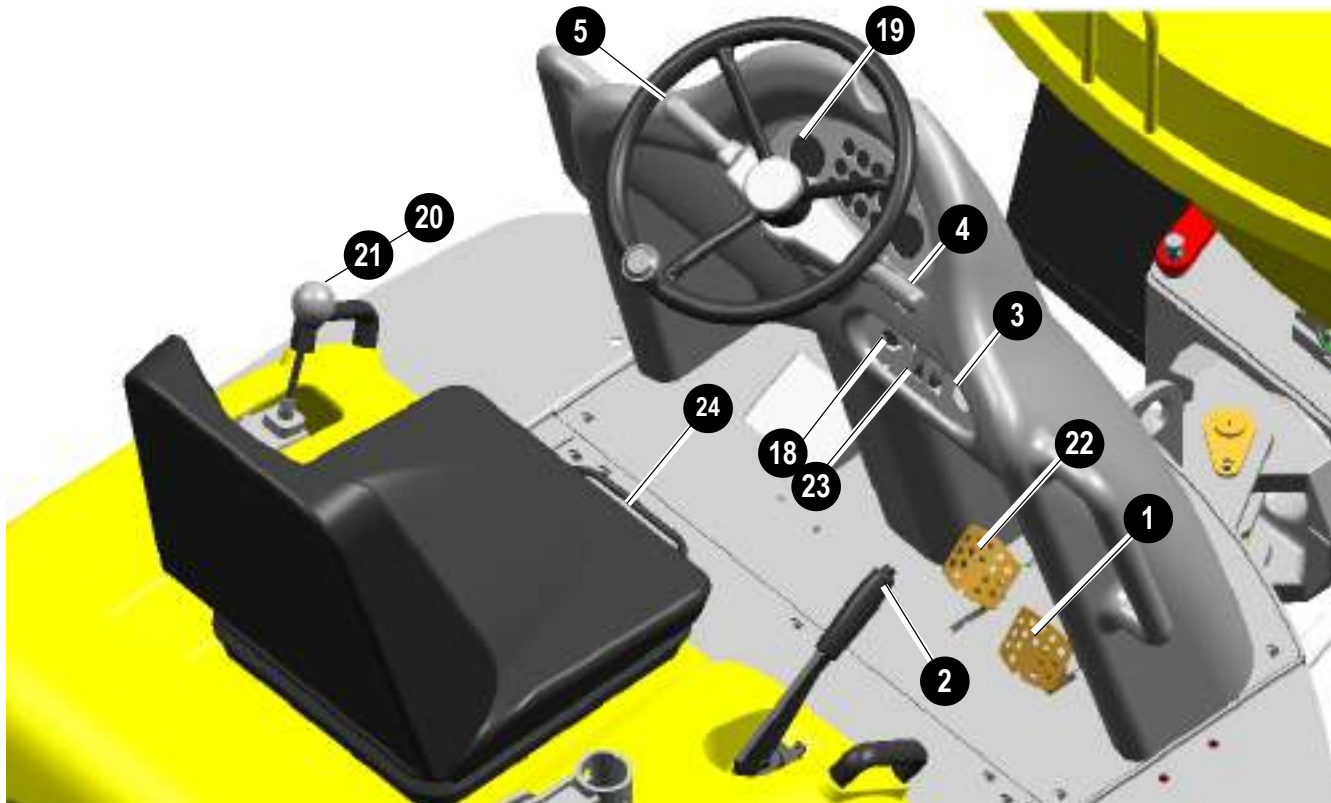
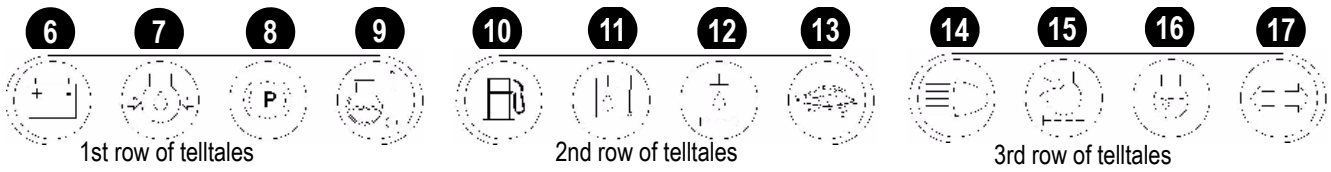
### 3.3 1001/1501/1501S operating equipment up to serial number AB ...

Pos.	Description
1	Accelerator pedal
2	Parking brake
3	Ignition lock
4	Forwards-reverse control
5	Horn
6	Alternator charge telltale
7	Engine oil pressure telltale
8	Parking brake telltale
9	Engine temperature telltale
10	Spare fuel telltale
11	Not assigned
12	Hydraulic oil filter telltale
13	Preheating telltale
14	Hour meter
15	Fuel level indicator
16	Lever "Dumping out/lowering the skip"
17	Lever "Raising/lowering the skip"
18	Bar for horizontal seat adjustment



### 3.4 1001/1501/1501S operating equipment from serial number AB ...

Pos.	Description
1	Drive pedal
2	Service brake
3	Parking brake
4	Ignition lock
5	Forwards-reverse control
6	Horn
7	Round indicating instrument
8	Alternator charge telltale
9	Engine oil pressure telltale
10	Parking brake telltale
11	Engine temperature telltale
12	Turn indicator telltale
13	Not assigned
14	Hydraulic oil filter telltale
15	Preheating telltale
16	Hour meter
17	Fuel level indicator
18	Lever "Dumping out/lowering the skip"
19	Lever "Raising/lowering the skip"
20	Bar for horizontal seat adjustment



### 3.5 2001/2001SLE operating equipment

Pos.	Description	Pos.	Description
1	Drive pedal	13	Not assigned
2	Parking brake	14	High beam telltale
3	Ignition lock	15	Not assigned
4	Forwards-reverse control	16	Preheating telltale
5	Horn	17	Turn indicator telltale
6	Alternator charge function telltale	18	Hour meter
7	Engine oil pressure telltale	19	Fuel level indicator
8	Parking brake telltale	20	Lever for tilting/lowering the skip
9	Engine temperature telltale	21	Lever: swivel skip
10	Spare fuel telltale	22	Hydrostatic brake pedal
11	Not assigned	23	Light switch
12	Hydraulic oil filter telltale	24	Seat adjustment lever

## 3.6 Putting into operation

### Safety instructions

- Use footholds and handles to access and leave the machine
- Never use control elements as handles
- Never get on or off a moving machine! Never jump off the machine

### Putting the machine into operation for the first time

#### Important information

- The machine may be put into operation by authorised staff only – [see chapter Selection and qualification of staff, basic responsibilities](#) on page 2-4 and – [see chapter 2.5 Safety instructions regarding operation](#) on page 2-5 of this Operator's Manual.
- The staff must have read and understood this Operator's Manual before putting the machine into operation.
- The machine may only be used in technically perfect condition in accordance with its designated use and the instructions set forth in the Operator's Manual, and only by safety-conscious persons who are fully aware of the risks involved in operating the machine.
- Go through the “Start-up” checklist in the following chapter.

### Running-in period

Handle the machine carefully during its first 50 operating hours.

The future performance and service life of the machine are heavily dependent on the observance of the following recommendations during the running-in period.

- Do not overload the machine, but at the same time do not drive too cautiously either, as the machine will never reach its proper operating temperature
- Do not run the engine at high speed for extended periods
- Increase the load gradually whilst varying the engine speed
- Strictly observe the maintenance schedules in the appendix – [see chapter 5.16 Maintenance plan 2001: overview](#) on page 5-37

## Check lists

The checklists below are intended to assist you in checking and monitoring the machine before, during and after operation.

These checklists cannot claim to be exhaustive; they are merely intended as an aid for you in fulfilling your duties as a conscientious operator.

The checking and monitoring jobs listed below are described in greater detail in the following chapters.

If the answer to one of the following questions is NO, first rectify the cause of the fault before starting or continuing work.

## Start-up checklist

Check the following points before putting the machine into operation or starting the engine:

No.	Question	✓
1	Enough fuel in the tank? (→ 5-4)	
2	Coolant level OK? (→ 5-11)	
3	Remove water in the diesel fuel prefilter (→ 5-5)	
4	Engine oil level OK? (→ 5-8)	
5	Oil level in hydraulic oil tank OK? (→ 5-18)	
7	V-belt condition and tension checked? (→ 5-15)	
8	Lubrication points greased? (→ 5-40)	
9	Check hydraulic hoses, connections and ram seals for leaks	
10	Firm position of battery terminals	
11	Tyres checked for cracks, cuts etc. ? (→ 5-23)	
12	Footholds clean?	
13	Engine cover locked with the buckle? (→ 3-25)	
14	Especially after cleaning, maintenance or repair work: → Rags, tools and other loose objects removed?	
15	Correct seat position? (→ 3-23)	
16	Rollbar raised?	
17	Seat belt fastened? (→ 3-24)	



**Operation checklist**

After starting the engine and during operation, check and observe the following points:

No.	Question	✓
1	Anyone dangerously close to the machine?	<input type="checkbox"/>
2	Telltale for engine oil pressure and alternator charge function gone out? (→ 3-13)	<input type="checkbox"/>
3	Temperature indicators for engine coolant do not come on? (→ 3-13)	<input type="checkbox"/>
4	Accelerator and brake pedals working correctly? (→ 3-17)	<input type="checkbox"/>

**Parking checklist**

Check and observe the following points when parking the machine:

No.	Question	✓
1	Skip lowered?	<input type="checkbox"/>
2	Drive lever in neutral position?	<input type="checkbox"/>
3	Parking brake applied?	<input type="checkbox"/>
4	Ignition key removed?	<input type="checkbox"/>
<b>When parking on public roads:</b>		
5	Machine adequately secured?	<input type="checkbox"/>
<b>When parking on slopes:</b>		
6	Machine additionally secured with chocks under the wheels to prevent it from rolling away?	<input type="checkbox"/>

### 3.7 Driving the dumper

#### Preheating start switch: overview

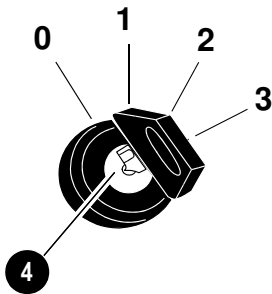


Fig. 26: Preheating start switch

Position	Function	Power consumer
0	Insert or remove the ignition key	None
1	ON/drive position	All functions are operational ➔ Telltales come on
2	Preheats the engine (10 – 15 seconds)	➔ Until the preheating telltale goes out
3	Starts the engine	➔ Starter is actuated ➔ Telltales must go out

#### Accelerator pedal: overview

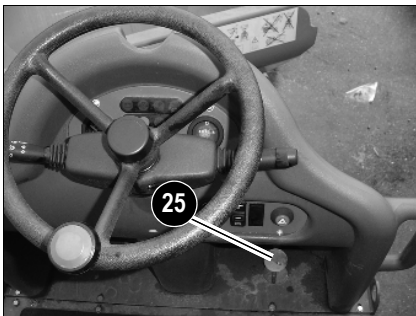


Fig. 27: Accelerator pedal

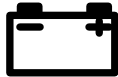
The accelerator pedal controls the revs as follows:

- Speed can be set continuously with accelerator pedal 25
  - ☞ Press down the accelerator pedal:
    - ➔ Engine speed rises
  - ☞ Reduce the pressure on the accelerator pedal:
    - ➔ Engine speed is reduced

**Telltale and warning lights: overview****14 Hydraulic oil filter telltale (red)**

Indicates inadmissibly high pressure in the hydraulic reflux line to the tank. In this case:

- ☞ Have the hydraulic oil reflux filter checked and, if necessary, replaced by an authorised workshop
- ☞ The telltale can come on briefly if the hydraulic oil is cold, but goes out again once operating temperature is reached.

**8 Telltale (red) – alternator charge function****Caution!**

The coolant pump no longer runs if the V-belt is faulty. Danger of engine overheating or breakdown!

If telltale comes on with the engine running:

- ☞ Stop the engine immediately and
- ☞ Have the cause repaired by an authorised workshop

The V-belt or the charging circuit of the alternator is faulty if the telltale comes on with the engine running. The battery is no longer charged.

**9 Engine oil pressure telltale (red)**

Comes on if the engine oil pressure is too low. In this case:

- ☞ Stop the machine
- ☞ Stop the engine immediately and check the oil level

The telltale comes on when the ignition is turned on and goes out as soon as the engine runs.

**11 Coolant temperature telltale (red)****Danger!**

Never open the radiator and never drain coolant if the engine is warm since the cooling system is under high pressure

–

**Danger of burns!**

- ☞ Wait at least 10 minutes after stopping the engine!
- ☞ Wear protective gloves and clothing
- ☞ Open the cap to the first notch and release the pressure

**15 Preheating telltale (yellow)**

Comes on if the key in the preheating start switch is in position **2**.

A glow plug preheats the air in the combustion chamber of the engine when the key is in this position.

The telltale goes out as soon as preheating temperature is reached (15 – 20 sec)



13 Not assigned



10 Parking brake telltale (red)

Comes on if the parking brake is applied!

In this case:

☞ Actuate lever 2 to release the parking brake

High beam telltale (blue)



Comes on if high beam is on.



**Caution!**

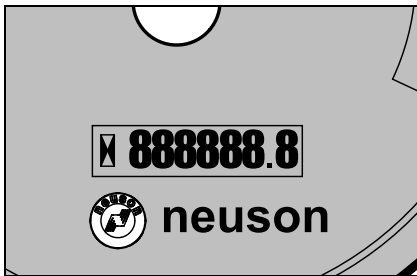
Make sure no other road users are dazzled during road travel!

☞ Switch on low beam



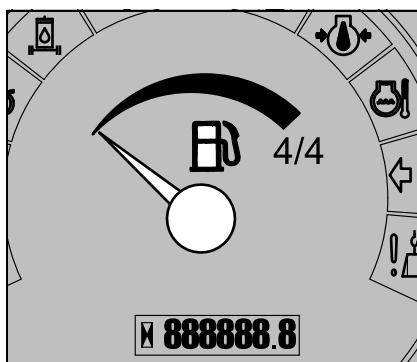
12 Turn indicator telltale (green)

Flashes if the turn indicators are switched on.



16 Hour meter

Counts the engine service hours with the engine running.



17 Fuel level indicator

Refuel immediately if the fuel level indicator reaches minimum. Otherwise the fuel system must be bled if it is run dry.

**Before starting the engine**

☞ *Adjust your seat position – see **Seat adjustment** on page 3-23*

**i Notice!**

All controls must be within easy reach. You must be able to press the accelerator and brake pedals to their limit positions!

☞ *Fasten your seat belt – see **Seat belt** on page 3-24*

- Do not fasten your seat belt if the rollbar is not raised!

☞ *Check whether all levers and pedals are in neutral position*

☞ *Press the accelerator pedal to the centre position (between minimum and maximum) if the engine is cold*

**Starting the engine: general**

- The starter cannot be actuated if:
  - the engine is already running (start repeat interlock).
  - the drive lever is not in neutral position,
  - the parking brake is not applied.
- Do not run the starter for more than 10 seconds
- Wait about 1 minute so the battery can recover before trying again

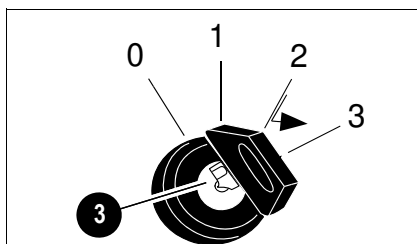
**Procedure**


Fig. 26: Preheating start switch

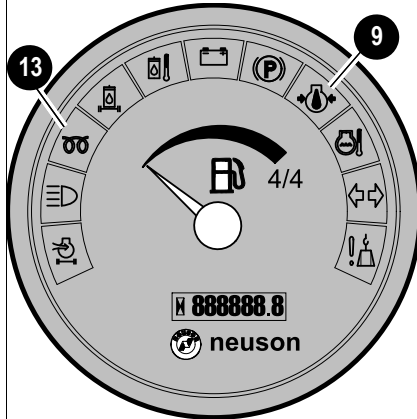


Fig. 27: Telltales

After you have completed the starting preparations:

☞ *Insert the ignition key in preheating start switch **3***

☞ *Turn the ignition key to position “1”*

☞ *Check whether the following telltales come on:*

- ➔ Telltale **9** for engine oil pressure
- ➔ Telltale **13** for alternator charge function

☞ *Replace defective telltales immediately*

☞ *Turn the ignition key to position “2” and hold it in this position until the preheating telltale goes out*

☞ *Turn the ignition key to position “3” and hold it in this position until the engine starts*

- ➔ If the engine does not start after 10 seconds
- ☞ Interrupt the start procedure and try again after 1 minute
- ➔ If the engine still does not start after the second try
- ☞ Contact a Wacker Neuson workshop for troubleshooting.

➔ *As soon as the engine runs:*

☞ *Release the ignition key*

When the engine runs smoothly (increased engine speed):

**i Notice!**

In general, a battery delivers less energy in cold conditions. Therefore make sure the battery is always well charged.

## When the engine has started ...

- ☞ Check whether all telltales have gone out:
- ☞ Let the engine warm up

At cold temperatures:

- ☞ Increase the engine speed slowly
- ☞ Do not run the engine at full load until it has reached its operating temperature

## Engine warm-up

Once it has started, let the engine warm up at slightly increased idling revs. Run the engine without load during the warm-up phase (drive lever in neutral position). During the warm-up phase, check for unusual noise, exhaust colour, leaks, malfunctions or damage. In case of malfunctions, damage or leaks, park and secure the machine, and find out the cause for the damage and have it repaired.

## Jump-starting the engine (supply battery)

### Safety instructions

- Never jump-start the engine if the battery of the machine is frozen – danger of explosion!
  - ☞ Dispose of a frozen battery!
- The excavator must not touch the jump-starting vehicle when connected with jump leads – risk of sparking!
- The external power source must deliver 12 V; higher supply voltages will damage the electrical system of the vehicles!
- Use only authorised jump leads which conform to the safety requirements and which are in perfect condition!
- The jump lead connected to the positive + terminal of the starting battery must never be brought into connection with electrically conductive vehicle parts – **danger of short circuit!**
- Route the jump leads so they cannot catch on rotating components in the engine compartment!

### Procedure

- ☞ Drive the jump-starting vehicle close enough to the machine so that the jump leads can reach to connect the two batteries
- ☞ Let the engine of the jump-starting vehicle run
- ☞ First connect one end of the red jump lead (+) to the + terminal of the flat battery, then connect the other end to the + terminal of the starting battery
- ☞ Connect one end of the black jump lead (–) to the – terminal of the starting battery
- ☞ Connect the other end of the black jump lead (–) onto a solid metal component firmly mounted on the engine block or onto the engine block itself. Do not connect it to the negative terminal of the flat battery, as otherwise explosive gas emerging from the battery can ignite if sparks are formed!
- ☞ Start the engine of the machine with the flat battery

### Once the engine has started:

- ☞ With the engine running, disconnect both jump leads in exactly the reverse order (first remove the – terminal, then the + terminal) – this prevents sparking in the vicinity of the battery!

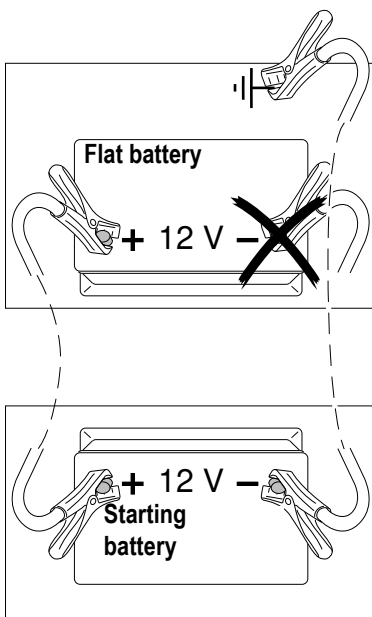


Fig. 28: Starting aid with jump leads

**Special instructions for driving on public roads**

The machine is subject to the:

- Applicable legal regulations of your country

Also observe the applicable regulations for accident prevention of your country.

**Moving off**



**Danger!**

Before pressing accelerator pedal **1**, move the drive lever to the correct position for the required driving direction!

**Danger of accidents!**

*☞ Slowly press the accelerator pedal to move off!*

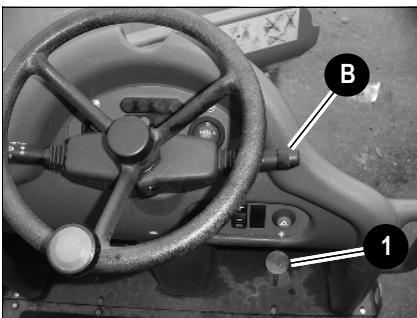


Fig. 29: Moving off

- Select the driving direction with drive lever **B**
- ☞ *Select the required driving direction*
- ☞ *Move off by pressing accelerator pedal **1***
- ☞ *The dumper brakes automatically to a standstill when releasing the accelerator pedal. Press and release the accelerator pedal slowly to avoid jerky movements of the dumper.*
- ☞ *Press the hydrostatic brake pedal **27** to brake the machine quickly (fig. 25)*
- ☞ *Apply the parking brake to park the dumper on slopes.*



**Caution!**

No changing over the driving direction when driving the machine

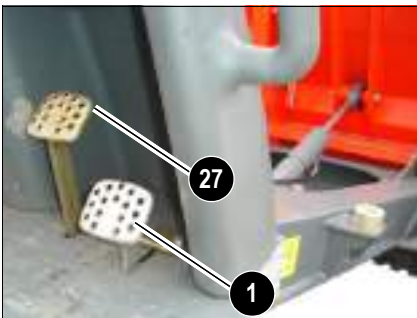


Fig. 30: Accelerator pedal

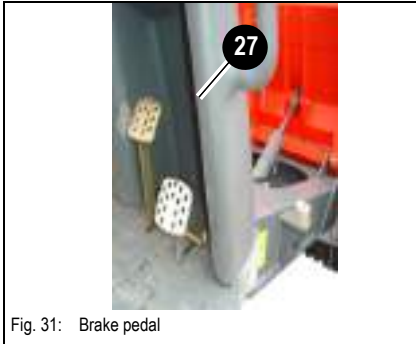
- Selecting another driving direction with the drive lever:
- ☞ *Stop the machine*
- ☞ *Select the required driving direction*
- ☞ *Move off by pressing accelerator pedal **1***

Accelerator pedal **1** sets the engine speed. During drive operation, the dumper is accelerated as revs are increased. During skip operation, the skip dumps in or out more rapidly as revs are increased.

Function	
Press the pedal	Engine speed rises
Reduce the pressure on the pedal	Engine speed is reduced
Release the pedal	Idling speed

The forwards or reverse drive speed depends on the position of accelerator pedal.

Hydraulic brake



Hydrostatic drive.

**Service brake 2** has its effect on the hydrostatic drive. The hydraulic parking brake in the rear wheel motors is enabled when pressing the brake pedal to the end position (2001: in the front wheel motors)

**i Notice!**

Use service brake **2** on slopes to slow down the machine as required.

Mechanical brake

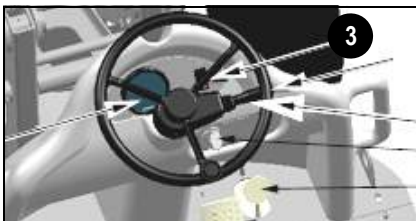


Fig. 32: Parking brake 1001/1501

Parking brake with mechanical braking effect on the front axle.

Press parking brake **3** forwards to release it.

**i Notice!**

Hitting parking brake **2** with your hand to release it can damage the lever!



Fig. 32: Parking brake 2001

Pull up the lever to apply parking brake **10**.

3.8 Hazard warning system

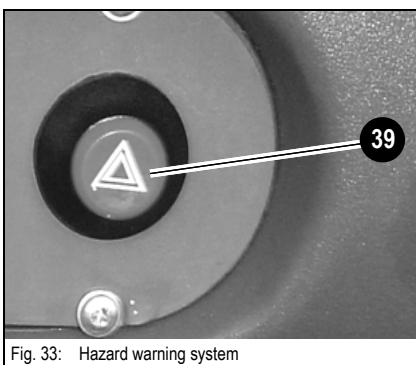


Fig. 33: Hazard warning system

Pressing switch **39** switches the hazard warning system on and off.



### 3.9 Driving on slopes

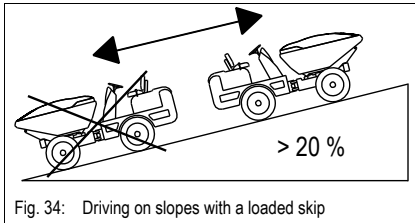
Follow these safety instructions carefully when driving on slopes, in order to avoid accidents.

#### Specific safety instructions



- ⓘ *Dump in the skip when driving the machine.*
- ⓘ *Also drive in low speed on slopes!*
- ⓘ *When driving the machine, make sure you can stop safely any time if the machine starts to skid or if it becomes unstable.*
- ⓘ *Avoid swivelling the skip downhill on slopes, otherwise the machine can lose its balance and tip over.*
  - ➔ *Always dump out the skip uphill.*
- ⓘ *Do not drive across slopes steeper than 20 % otherwise the machine can tip over laterally.*
- ⓘ *Always drive straight ahead when driving uphill or downhill. Driving diagonally or at an angle to the slope is very dangerous.*
- ⓘ *Drive slowly in meadows, on leaves or wet steel plates. The machine can slip even if the ground is level.*

## Driving on slopes with a loaded skip



Proceed as follows to prevent the machine from tipping over or slipping sideways:

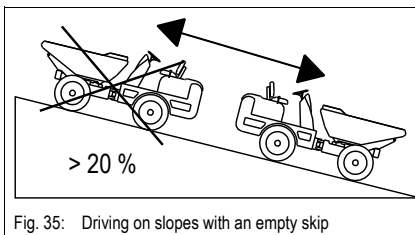
- ☞ When driving on slopes (> 20 %) with a loaded skip, the skip must always face uphill since the heavier part of the machine – in this case the load in the skip – must face uphill to prevent the machine from tipping over.



### Danger!

Drive on slopes only on firm ground!

## Driving on slopes with an empty skip



- ☞ When driving on slopes (> 20 %) with an empty skip, the skip must always face downhill since the heavier part of the machine – in this case the engine – must face uphill to prevent the machine from tipping over.

## Driving across slopes

- ☞ Do not drive across slopes with lateral inclinations steeper than 20 %!
- ☞ When driving across slopes with lateral inclinations up to 20 %, dump out the skip only uphill for reasons of safety.



### Danger!

Pay special attention to the ground when driving across slopes –

### Danger of accidents!

- ☞ Driving across slopes up to 20 % steep is allowed only on firm ground.

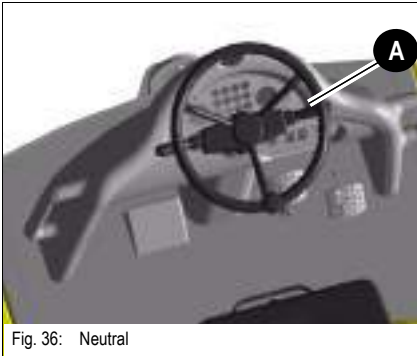
**Parking the machine**

Fig. 36: Neutral

**Danger!**

Always park the machine on firm ground!

**Danger of accidents**

- ☞ Select a level surface
- ☞ Stop the machine
- ☞ Move drive lever **A** to neutral position
- ☞ Lower the skip
- ☞ Apply the parking brake
- ☞ Switch off ignition
- ☞ If parking the machine on a slope cannot be avoided, place wheel chocks under the wheels to make sure the machine will not roll away under its own weight.

**Caution!**

Never stop the engine under full load, otherwise it can be damaged due to overheating. Let the engine briefly run at idling speed with no load before you switch it off.

**Notice!**

Secure the machine against unauthorised operation.

- Remove the key.

## Loading the machine



### Danger!

Always stay clear of the machine as you load it with an excavator or other machines –

### Danger of personal injury!



### Caution!

Incorrect loading causes severe damage on the machine.

- ☞ *Make sure the payload is not exceeded!*
- ☞ *Make sure the driver's visibility is not impaired.*

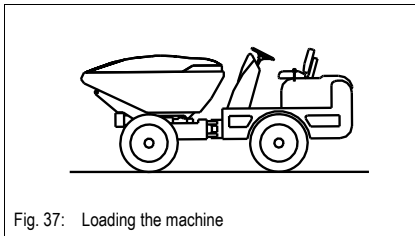


Fig. 37: Loading the machine

- Before loading:
  - ☞ *Select the neutral position with the drive lever*
  - ☞ *Lower the skip*
  - ☞ *Apply the parking brake*
  - ☞ *Stay clear of the control stand and of the danger area for reasons of safety*
  
- Once loading is over:
  - ☞ *Remove dirt, debris, dust etc. from the control elements*
  - ☞ *Remove loose material*

### 3.10 Seat adjustment



#### **Danger!**

Never change the seat position when driving or working – see **Before starting the engine** on page 3-15

#### **Danger of accidents!**

☞ *Adjust the seat before moving the machine*

#### Weight adjustment



#### **Notice!**

Adjust the seat suspension correctly to ensure a high level of ride comfort.



Fig. 38: Weight adjustment

To adjust to a higher weight:

☞ *Turn the adjusting wheel to the right.*

To adjust to a lower weight:

☞ *Turn the adjusting wheel to the left.*

The specified weight is indicated by the yellow pointer next to the adjusting wheel.

#### Horizontal adjustment



Fig. 39: Horizontal seat adjustment

☞ *Sit down on the seat*

☞ *Pull lever 33 upwards and at the same time*

☞ *Move the seat forwards or backwards.*

#### Backrest adjustment



Fig. 40: Backrest adjustment

☞ *Pull lever 29 up and at the same time press against the backrest to move it to the required position.*

☞ *Let lever 29 lock into place.*

### 3.11 Seat belt



#### Danger!

Do not drive or work with the seat belt unbuckled –

#### Danger of personal injury!

Buckle up before moving or working with the machine!

- Always fasten the seat belt if the rollbar is raised!
- Do not use the seat belt if the rollbar is lowered.
- Seat belt must not be twisted!
- The seat belt must run over the hips – and not over the stomach!
- Do not place the seat belt over hard, edged or fragile items (tools, meter rule, glasses, pen) carried inside your clothes!
- Never buckle up 2 persons (children!) with one seat belt!
- Check seat belts regularly. Have damaged parts immediately replaced by an authorised workshop!
- Always keep the seat belt clean, as coarse dirt can impair proper functioning!
- Seat belt buckle must not be obstructed by foreign bodies (paper or similar); otherwise the buckle latch cannot lock into place!

After an accident the belt strap is stretched and no longer serviceable. In an accident, the seat belt

#### Will not provide adequate protection!

- Replace the seat belt after an accident
- Have fastening points and seat fixture checked for bearing capacity!

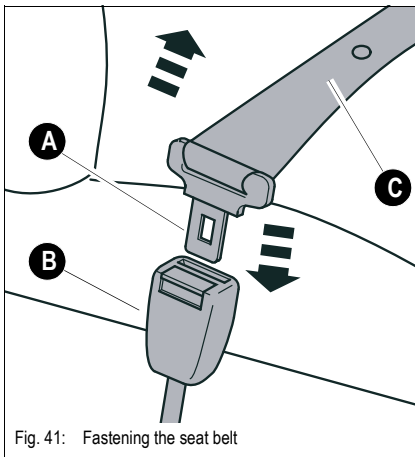


Fig. 41: Fastening the seat belt

Seat belt **C** is for the driver's safety during work on construction sites and during road travel.

#### Fastening the seat belt:

Fasten seat belt **C** as follows before moving the machine:

- Hold belt on buckle latch **A** and run it slowly and steadily over the hips to buckle **B**
- Insert buckle latch **A** into buckle **B** with an audible click (**pull test**)



#### Notice!

Fasten the seat belt only if the rollbar is raised.

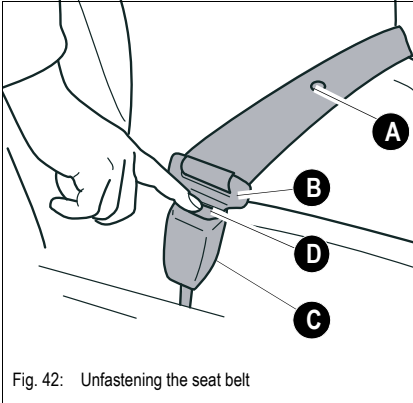


Fig. 42: Unfastening the seat belt

**Unfastening the seat belt:**

☞ Unfasten seat belt **A** as follows:

- Hold the seat belt
- Press red button **D** on buckle **C**
  - ➔ Latch **B** is released from buckle **C** by spring pressure
- Slowly return the seat belt to the retractor

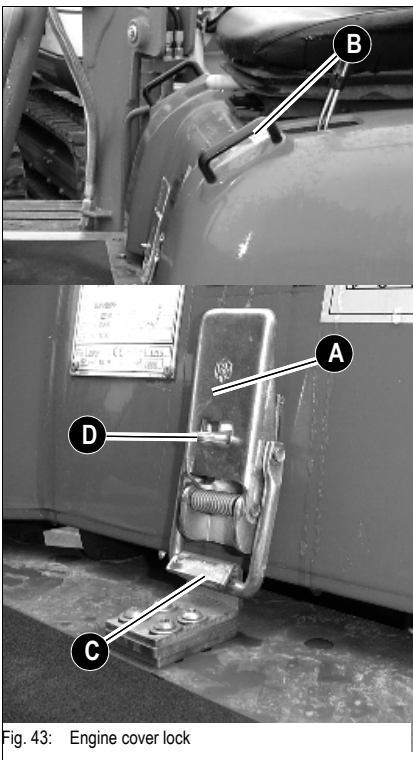
**Engine cover**


Fig. 43: Engine cover lock

**Opening:**

- ☞ Stop the machine
- ☞ Let the engine cool down
- ☞ Press buckle **A** of the engine cover downwards and pull shackle **C** to the front
- ☞ Pull the engine cover up with handle **B**

**Closing:**

- ☞ Press down the engine cover
- ☞ Press buckle **A** forwards and hitch shackle **C** into the hook at the same time
- ☞ Press lock **A** to the rear

**Locking and unlocking:**

The engine cover can be locked with an external lock in eyelet **D**


**Notice!**

Do not lock the engine cover during machine operation!  
The emergency switch is located underneath the engine cover!

### 3.12 Working with the machine

#### General safety instructions

- Never drive up to the edge of a pit from outside – danger of cave-in!
- Do not drive underneath projecting earth. Stones or the projecting earth can fall onto the machine.
- When working on roofs or similar structures, check the resistance and the structure itself before starting work. The building can collapse, causing severe injury and damage.
- Do not place the machine directly underneath the workplace during demolition, otherwise demolished parts can fall onto the machine or the building can collapse, causing severe injury or damage.
- Operation of the machine by unauthorised staff is prohibited!
- The hydraulic system of the machine is still pressurised even when the engine is not running! Release the pressure in the sections of the system and hydraulic lines which are to be opened before starting setup or repair work.
- Before dumping out the skip next to an excavation, secure the machine with suitable wheel chocks or other auxiliary means.
- Always watch the material as you dump out the skip: make sure the material is dumped out evenly and does not remain stuck in the skip, otherwise the machine could tip over
- Do not dump the load when working on sloping ground.
- No transporting of persons, animals etc. in the skip.
- Driving with a dumped-out skip is prohibited!
- Always carry out precise and smooth control movements, do not carry out abrupt movements.
- Do not get on or off the machine when it is moving.
- Avoid dangerous work conditions on the work site, do not work in severe weather and make sure no-one is at risk.
- Always fasten your seat belt when working with machines with rollover protection structures.



### 3.13 High-tip skip operation (1001 + 1501H + 1501S)

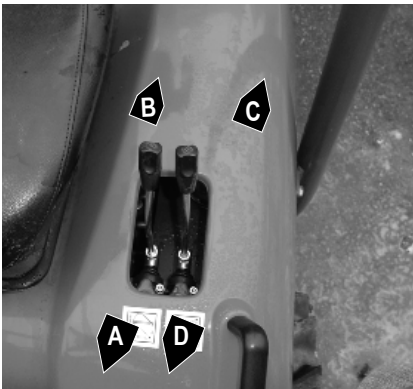


Fig. 44: Dumping in and out (1001/1501H)

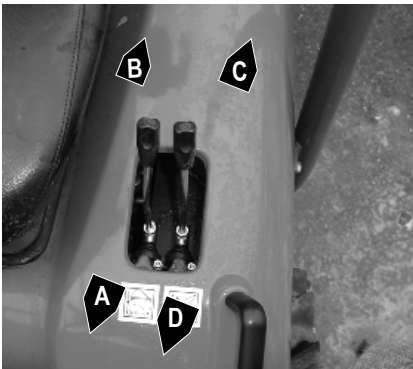


Fig. 44: Dumping in and out 1501S



#### Caution!

Driving with a dumped-out skip is prohibited!

Material that sticks in the skip may be dumped out only to the front in the straight-ahead position of the dumper.

The working speed of the skip is set with the travel of the control lever and with the accelerator pedal.

When dumping material into a pit, a firm resistance (beam) is required for propping the front wheels!

⚠ *Never drive up to a pit only with the brakes!*

Lowering the skip too rapidly and knocking it against the chassis can cause damage and the dumper to tip over!

Set the skip to the required position before dumping out the skip.

#### High-tip skip operation (1001 + 1501H)

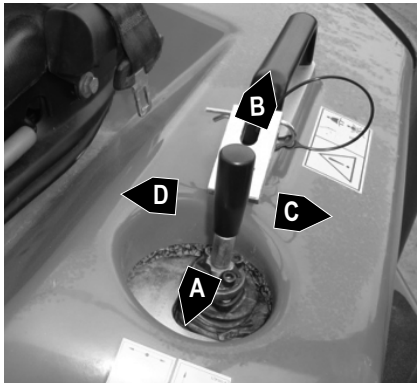
Position	Lever	Function
A	☞ Lever forwards	☞ Raises the skip
B	☞ Lever pulled backwards	☞ Lowers the skip
C	☞ Lever to the left	☞ Dumps in the skip
D	☞ Lever to the right	☞ Dumps out the skip

#### High-tip skip operation (1501S)

Position	Lever	Function
A	☞ Lever forwards	☞ Skip swivels to the left
B	☞ Lever pulled backwards	☞ Skip swivels to the right
C	☞ Lever to the left	☞ Dumps in the skip
D	☞ Lever to the right	☞ Dumps out the skip

- The control levers for skip operation (raising, lowering, swivelling, dumping in and out) are at the left of the seat.
- Swivel and empty the skip only on a level surface, in straight-ahead position of the dumper
  - ☞ See label on the right on the skip.

### 3.14 Swivel skip operation



#### Caution!

Driving with a dumped-out skip is prohibited!

The working speed of the skip can be adjusted with the control lever and the accelerator pedal.

When dumping material into a pit, a firm resistance (beam) is required for propping the front wheels!

⚠ *Never drive up to a pit only with the brakes!*

Lowering the skip too rapidly and knocking it against the chassis can cause damage and the dumper to tip over!

- The control levers for skip operation (raising, lowering, swivelling, dumping in and out) are at the left of the seat.
- Swivel and empty the skip only on a level surface, in straight-ahead position of the dumper
  - ➔ See label on the right on the skip.

#### Swivelling the skip:

Before swivelling the skip, press the lever forwards to raise it until the lock cog is raised from the lock recess.

The skip can then be swivelled.

- ➔ The normal position of the skip is the position in which the skip is in centre position and in which the lock cog engages in the lock recess.

Position	Lever	Function
A	⚡ Lever forwards	➔ Dumps out the skip
B	⚡ Lever pulled backwards	➔ Lowers the skip
C	⚡ Lever to the left	➔ Skip swivels to the left
D	⚡ Lever to the right	➔ Skip swivels to the right

### 3.15 Loader unit (2001 SLE)



Fig. 45:

The loader unit has been designed for raising loose material up to 300 kg. The 2001 SLE is not suitable for excavating or pushing heavy material.

Bear in mind the following when using the 2001 SLE:

- ⚡ Skip must be lowered when loading.
- ⚡ • Always lower the loader unit before dumping out or rotating the skip.
- ⚡ • Do not use the loader unit on slopes.
- ⚡ • Other persons must stay clear of the dumper during work
- ⚡ • Bucket must be in a horizontal position when pushing or picking up material (see mark on bucket ram).
- ⚡ • Dumper must be in a straight position when pushing or picking up material (no steering).
- ⚡ • Never use the loader unit as a crane.
- ⚡ • Lower the bucket onto the skip when driving the dumper.



**Danger!**

Load material only with the skip and the dumper in a straight position!  
Damage can result if the loader unit hits the skip!

---

Bucket teeth towards the rear side of the skip.

Avoid dumping out the bucket too fast otherwise the material can be thrown beyond the skip.

Empty the bucket slowly (lever to the left)! Check whether the loader unit is lowered before rotating the skip. The skip can be dumped out to the right or left, or to the front through the lowered arms of the loader unit.

Avoid dumping material onto the loader unit.

Raise the bucket only with the skip in a lowered and straight position.

- For light grading work, empty the skip and rotate it to the side if it is not required for working. This gives you good visibility of the bucket. Reverse when grading, and press and hold the lever downwards and to the front (no float position).
- The bucket has not been designed for transporting material. No excavating!
- The bucket of the 2001 SLE is not comparable with a wheel loader bucket.

### 3.16 Information on working with the loader unit

- The loader unit bucket is no earthmoving tool! Load only bulk material. The loader unit has not been designed for higher forces.
- Always engage 1st speed and do not steer the wheels when driving against a pile of material. Always move the bucket flat on the ground before picking up material.
- When penetrating into a pile with the bucket, fully dump in the bucket (lever to the left). Avoid spinning the wheels: this can cause damage to the drive, or the wheels to dig into the ground on loose ground.
- Raise the bucket out of the material (lever to the rear). If there is too much material in the bucket, reverse a little to remove a little material from the bucket. Raise the bucket until you can see it over the front edge of the skip.
- Avoid losing material by carefully dumping out the bucket (lever to the right) and by raising the whole loader unit at the same time (lever diagonally to the rear right).
- Keeping the bucket in a parallel position requires a little practice.

### 3.17 Rollbar

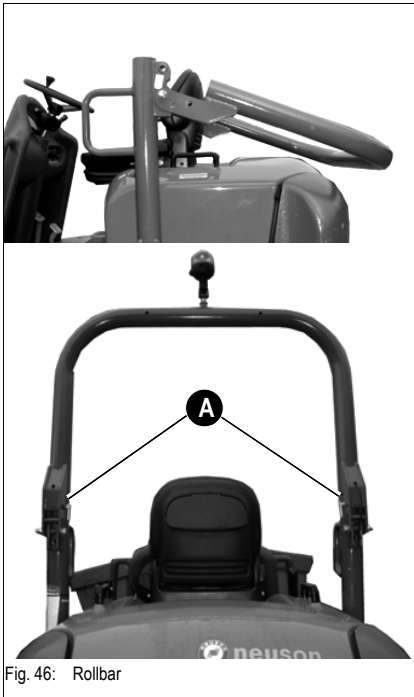


Fig. 46: Rollbar



#### Danger!

The rollbar is very heavy, folding it up or down is very

#### Dangerous!

☞ *Two persons are required for raising or lowering the rollbar.*



#### Caution!

Do not fasten the seat belt when driving with the rollbar lowered!

#### Raising the rollbar:

- ☞ *Place the machine on level ground*
- ☞ *Raise the rollbar*
- ☞ *Fasten the rollbar with lock pins **A** and secure these pins with split pins*

#### Lowering the rollbar:

- ☞ *Place the machine on level ground*
- ☞ *Remove the split pins from lock pins **A***
- ☞ *Remove lock pins **A***
- ☞ *Slowly and carefully lower the rollbar with the help of a second person*

### 3.18 Towing 1001/1501/1501 S/2001

In order to tow away the dumper, the high-pressure circuit on the hydrostatic pump must be opened and the hydraulic parking brake on both rear wheel motors must be released.

#### Opening the high-pressure circuit 1001/1501/1501 S

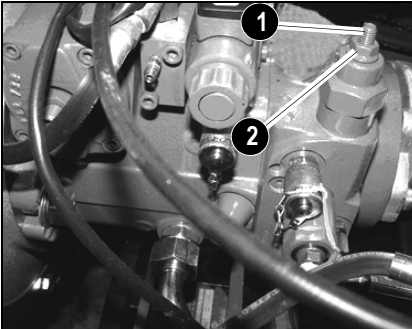


Fig. 47: Opening the high-pressure circuit

There are two HP pressure limiting valves on the pump under the floor panel, one on the upper left and the other on lower left.

Proceed as follows:

- ☞ Slacken locknut ws 14 (part 2) and unscrew it to the end of the screw
- ☞ Screw in the screw with an allen key ws 4 part 1 until it is flush with the nut.

Then screw in a further half revolution.



#### **Danger!**

Screwing in any further damages the valve!

- ☞ Retighten the locknut

- ☞ \* You can now slowly tow the machine (max. 2 kph) over a short distance (max. 1 km) Then put the valves back into operation again.

Proceed in the reverse order to do this (unscrew the screw as far as it will go)

### 3.19 Releasing the hydraulic parking brake 1001/1501/1501 S

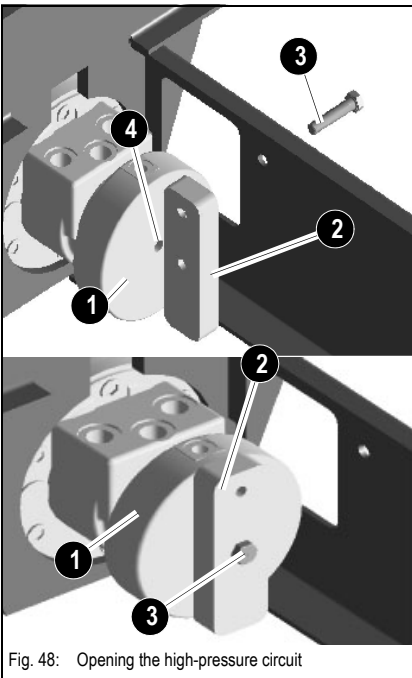


Fig. 48: Opening the high-pressure circuit

- ☞ Remove both extraction units (2) mounted on the rear axle body to release the hydraulic parking brake (1). Remove hexagon head screw (3) M12x35 (ws 19) to this effect.

- ☞ Remove the plastic plugs (4) in the middle on the face of the wheel motors.

- ☞ Place the extraction unit on the face of the wheel motor and fasten it with screw M12x35.

- ☞ Tighten the screw to 42 Nm until the wheel turns freely

### 3.20 Opening the high-pressure circuit 2001

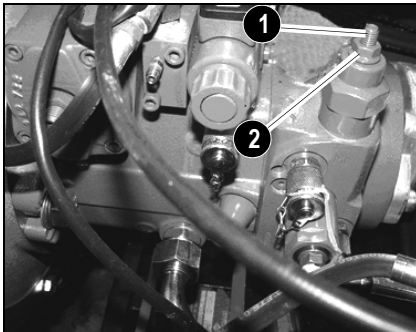


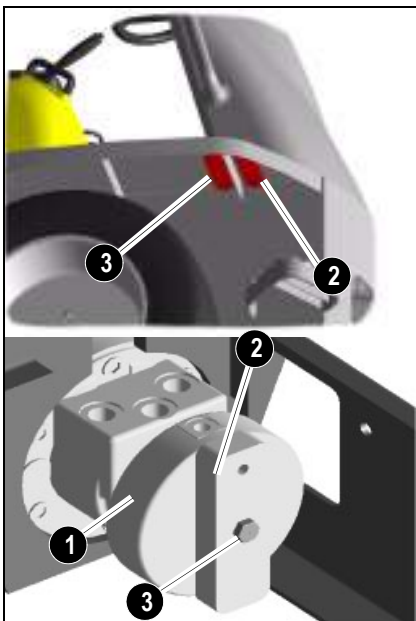
Fig. 49: Opening the high-pressure circuit

There are two HP pressure limiting valves on the pump under the floor panel, one on the upper left and the other on lower left.

Proceed as follows:

- ☞ Slacken locknut ws 14 (part 2) and unscrew it to the end of the screw
- ☞ \* Screw in the screw with an allen key ws 4 part 1 until it is flush with the nut
- ☞ \* Retighten the locknut
- ☞ \* You can now slowly tow the machine (max. 2 kph) over a short distance (max. 1 km) Then put the valves back into operation again. Proceed in the reverse order to do this (unscrew the screw as far as it will go)

### 3.21 Releasing the hydraulic parking brake 2001



- ☞ Remove both extraction units (2) mounted at the front on the mudguard to release the hydraulic parking brake (1). Remove hexagon head screw (3) M12x35 (ws 19) to this effect.
- ☞ Remove the plastic plugs (4) in the middle on the face of the wheel motors.
- ☞ Place the extraction unit on the face of the wheel motor and fasten it with screw M12x35.
- ☞ Tighten the screw to 42 Nm until the wheel turns freely

### 3.22 Centre pivot strut



**Danger!**

Put the red centre-pivot strut in place before loading the machine.

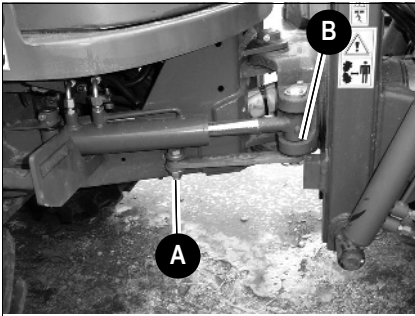


Fig. 50: Centre pivot strut

The centre pivot strut connects the front and rear chassis to prevent steering movements (via the articulated joint) when crane handling the dumper.

**Procedure to follow:**

- ☞ Remove the spring plug from pin **B**
- ☞ Turn centre pivot strut **A** towards the rear chassis
- ☞ Secure centre pivot strut **A** with the spring plug and pin **B**



**Notice!**

Before putting the machine into operation again, mount the centre pivot strut back onto the front chassis again by means of pin **B**.

### 3.23 Locking the control levers

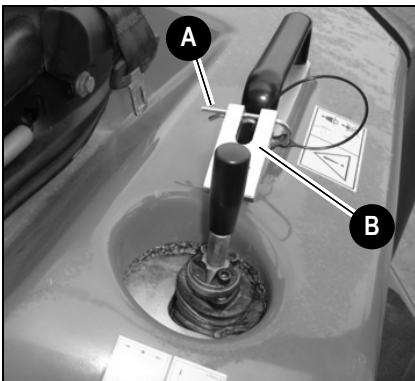


Fig. 51: Locking the control lever



**Caution!**

Lock the control lever for the skip during road travel!

- ☞ This avoids unintentional actuation of the skip.

Lock as follows:

- ☞ Remove split pin **A** from bracket **B**
- ☞ Fold bracket **B** to the front
- ☞ Insert split pin **A** in bracket **B**

Unlock in the reverse order!

### 3.24 Crane handling the machine

#### Safety instructions

- The crane and the lifting gear must have suitable dimensions.
- Crane handling the machine requires suitable lifting gear.
- Secure the machine against unintentional movement!



#### Danger!

Incorrect crane handling of the machine –

#### Danger of accidents!

- ☞ *Make sure no-one is near the machine!*
- ☞ *Have loads fastened and crane operators instructed by experienced persons only! The person giving the instructions to the crane operator must be within sight or sound of him!*
- ☞ *Make sure the crane and the lifting gear (cables, chains) have sufficient lifting capacity!*
- ☞ *Raise the machine only if the skip is empty!*
- ☞ *Stay clear of suspended loads!*
- ☞ *It is essential that you read the safety instructions at the beginning of this chapter and follow any other safety instructions relevant in your country!*

#### ☞ Load the machine as follows:

- Empty the skip
- Lower the skip
- Stop and park the machine
- Lock the control levers – see [chapter 3.23 Locking the control levers](#) on page 3-33
- The rollbar can be lowered to reduce the transport height.
- Put the centre pivot strut in place
- Use suitable lifting gear, chains etc.

#### 1001/1501/1501 S

Raise the dumper by hitching the lifting gear onto the eyelet. Do not hitch the lifting gear onto the handle.

- Fold in the centre pivot strut when raising the machine.

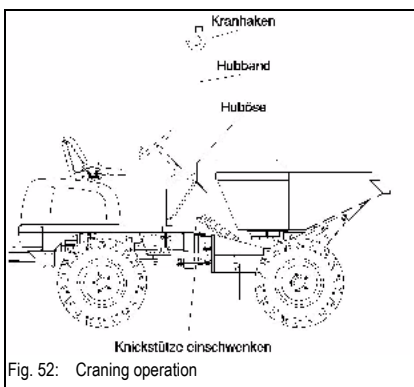


Fig. 52: Craning operation



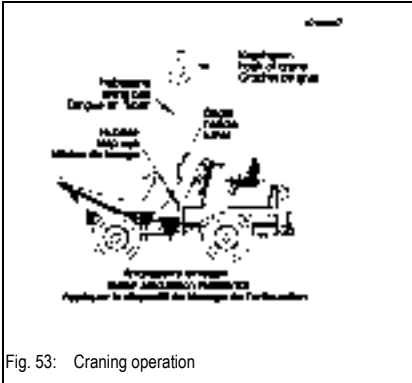


Fig. 53: Craning operation

### 2001/2001 SLE

Raise the dumper by hitching the lifting gear onto the eyelet on the rear chassis and make it go through the handle at the edge of the skip. Fold in the centre pivot strut when raising the machine.

## Loading and transporting the machine

### Safety instructions

- The transport vehicle must be of adequate size. Dimensions and weights of machine: see
- [Chapter 6 “Specifications \(1001 – 1501\)”](#)
- and [Chapter 6 “Specifications \(2001\)”](#).
- Remove any mud, snow or ice from the tyres so that the machine can be safely driven onto the ramps
- Secure the machine against unintentional movement – see [Parking the machine](#) on page 3-21!



### Danger!

The machine must be loaded and transported properly –

### Danger of accidents!

*It is essential that you read the safety instructions at the beginning of this chapter and follow any other safety instructions relevant in your country!*

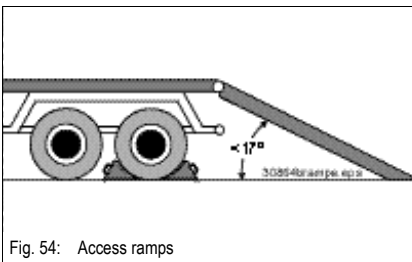


Fig. 54: Access ramps

### Load as follows:

- Secure the transport vehicle with chocks to prevent it from rolling
- Place the access ramps at the smallest possible angle. Make sure the grade does not exceed  $17^\circ$  (30 %). Use access ramps with an antiskid surface only.
- Make sure the loading area is clear and access to it is not obstructed – e.g. by super-structures
- Make sure the ramps and the tyres of the dumper are free of oil, grease and ice
- Start the engine of the dumper
- Lower the skip of the dumper
- Carefully reverse the dumper onto the middle of the transport vehicle
- Stop and park the machine



### Notice!

The manufacturer's warranty shall not apply to accidents or damage caused by loading or transporting the excavator.

Tying down the machine

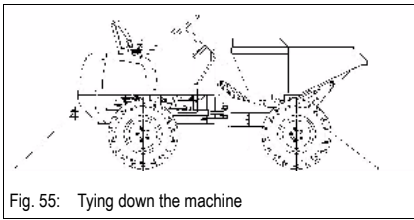


Fig. 55: Tying down the machine



**Danger!**

The machine must be loaded and transported properly –

**Danger of accidents!**

☞ *It is essential that you read the safety instructions at the beginning of this chapter and follow any other safety instructions relevant in your country!*

- Secure the wheels of the dumper at the front, rear and at the sides
- Two eyelets on the front chassis of the dumper and a pin on the rear chassis are used for this
- Make sure the driver of the transport vehicle knows the overall height, width and weight of his vehicle (including the dumper) before moving off, and the legal transport regulations of the country or countries in which transport will take place!

**3.25 Battery master switch 1001 – 1501**

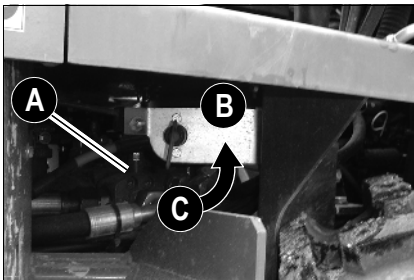


Fig. 56: Battery master switch



**Notice!**

Do not disconnect the battery while the engine is running.



**Notice!**

Power supply is interrupted directly after the battery, by means of a key

- *Before working on the electrical system*

**Interrupting power supply:**

☞ *Turn key A of the battery master switch to position B and remove it*

**Switching on power supply:**

☞ *Insert key A in the battery master switch*

☞ *Turn the key down to the notched position C*

The 2001 dumper has a Quickpower Plus terminal instead of a main switch.



## 4 Troubleshooting

The information given in this chapter is provided for maintenance staff, for fast and reliable detection of malfunctions and their appropriate repair.

Repairs must be carried out by authorised staff.

### 4.1 Engine trouble

Problem	Possible causes	See
Engine does not start or is not easy to start	Wrong SAE grade of engine lubrication oil	5-30
	Fuel grade does not comply with specifications	5-30
	Defective or flat battery	5-27
	Loose or oxidised cable connections in starter circuit	
	Defective starter, or pinion does not engage	
	Wrong valve clearance	
	Defective fuel injector	
Engine starts, but does not run smoothly or faultless	Fuel grade does not comply with specifications	5-30
	Wrong valve clearance	
	Injection line leaks	
	Defective fuel injector	
Engine overheats. Temperature warning system responds	Oil level too low	5-8
	Oil level too high	5-8
	Dirty air filter	5-13
	Dirty oil radiator fins	
	Defective fuel injector	
Insufficient engine output	Oil level too high	5-8
	Fuel grade does not comply with specifications	5-30
	Dirty air filter	5-13
	Wrong valve clearance	
	Injection line leaks	
	Defective fuel injector	
Engine does not run on all cylinders	Injection line leaks	
	Defective fuel injector	
Insufficient or no engine oil pressure	Oil level too low	5-8
	Machine inclination too high (max. 25°)	
	Wrong SAE grade of engine lubrication oil	5-30
Engine oil consumption too high	Oil level too high	5-8
	Machine inclination too high (max. 25°)	



Problem		Possible causes	See
Engine smoke	Blue	Oil level too high	5-8
		Machine inclination too high (max. 25°)	
	White	Engine starting temperature too low	
		Fuel grade does not comply with specifications	5-30
		Wrong valve clearance	
	Black	Defective fuel injector	
		Dirty air filter	5-13
		Wrong valve clearance	
		Defective fuel injector	

## 5 Maintenance

### 5.1 Introduction

Operational readiness and the service life of machines are heavily dependent on maintenance.

It is therefore in the interest of the machine owner to carry out the prescribed maintenance work.

Before carrying out service and maintenance work, always read, understand and follow the instructions given in:

- Chapter 2 “SAFETY INSTRUCTIONS” of this Operator's Manual

Carry out the prescribed inspections and rectify any disorders before putting the machine into operation.

Secure open (engine) covers appropriately. Do not open (engine) covers on slopes or in strong wind.

Dirt can be blown away and cause severe injuries when using compressed air. Always wear protective goggles, masks and clothing.

Daily service and maintenance work, and maintenance according to maintenance plan “A” must be carried out by a specifically trained driver. All other maintenance work must be carried out by trained and qualified staff only.

The maintenance plans indicate when the maintenance work mentioned below must be carried out – see **Maintenance plan 2001: overview** on page 5-37.

#### Front skip maintenance strut 1001

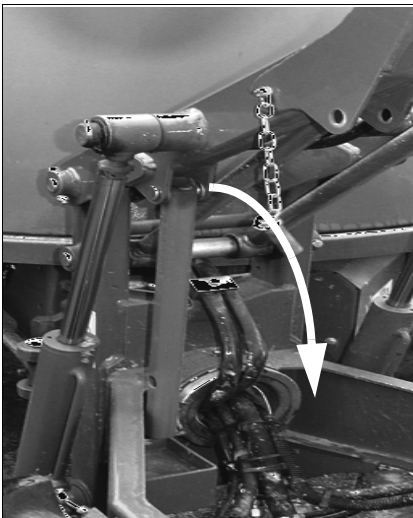


Fig. 26: High-tip skip maintenance strut



#### **Danger!**

Fold down the red maintenance strut before you carry out maintenance work with the skip raised.

This is carried out by:

- ☞ Pulling out spring plug and removing the pin.
- ☞ The maintenance strut shows downwards vertically and is automatically positioned in a socket in case the lift frame should be lowered.

## 5.2 Maintenance strut, model 1501

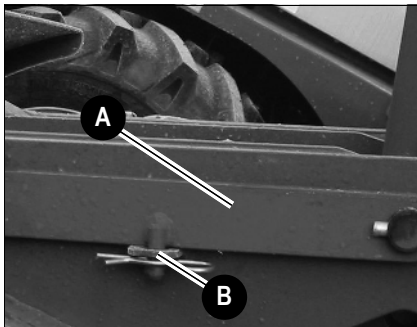


Fig. 27: Maintenance strut

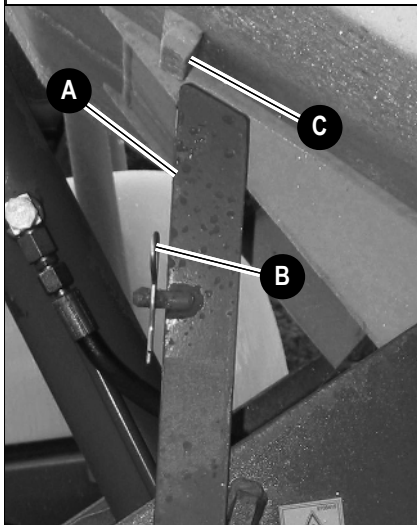


Fig. 28: Maintenance strut



### Danger!

Fold up the red maintenance strut before you carry out maintenance work with the skip dumped out.

The maintenance strut is upright and secured on the skip, thereby preventing the skip from being lowered.

#### Proceed as follows:

- ☞ Remove the split pin from pin **B**
- ☞ Fold up maintenance strut **A**
- ☞ Lower the skip until maintenance strut **A** is secured by safety device **C**



### Notice!

Fold down the maintenance strut in the reverse order once maintenance work is over.

### 5.3 Maintenance strut 2001

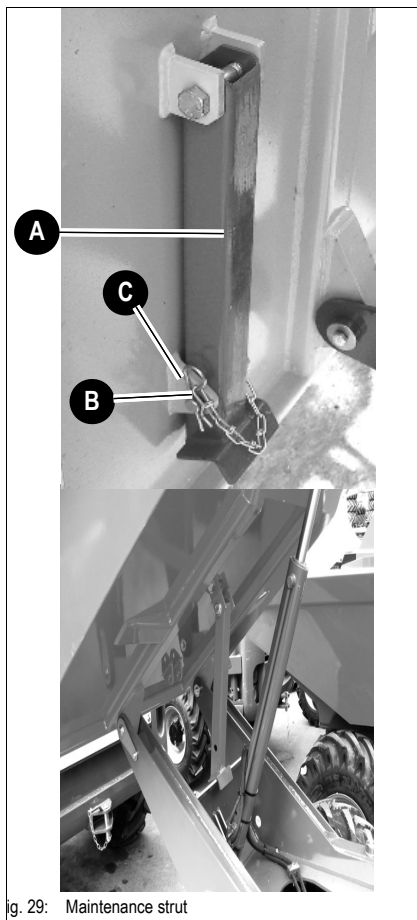


Fig. 29: Maintenance strut



#### **Danger!**

Fold down the red maintenance strut before you carry out maintenance work with the skip raised.

The maintenance strut shows downwards vertically and is automatically positioned on support **D** in case the skip should be lowered.

#### **Procedure to follow:**

- Remove the spring plug from pin **B**
- Remove the pin from guide **C**
- Fold down maintenance strut **A**



#### **Notice!**

Fold back the maintenance strut in the reverse order once maintenance work is over.

## 5.4 Fuel system

### Specific safety instructions

- Extreme caution is essential when handling fuel – high risk of fire!
- Never carry out work on the fuel system in the vicinity of naked flames or sparks!
- Do not smoke when working on the fuel system or when refuelling!
- Before refuelling, stop the engine and remove the ignition key!
- Do not refuel in closed rooms!
- Wipe away fuel spills immediately!
- Keep the machine clean to reduce the risk of fire!

### Refuelling

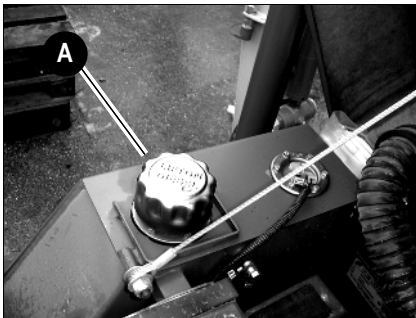


Fig. 30: Fuel filler inlet 1001/1501

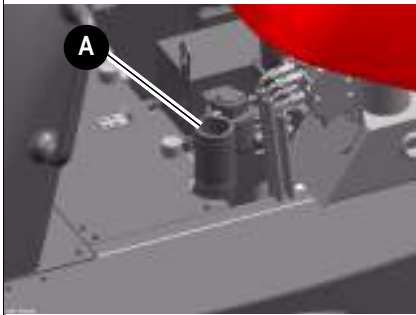


Fig. 30: Fuel filler inlet 2001

Filler inlet **A** for the fuel tank is located under the engine cover, on the right in driving direction.



### Danger!

All work involving fuel carries an increased

### Danger of fire and poisoning!

- ☞ Do not refuel in closed rooms
- ☞ Never carry out work on the fuel system in the vicinity of naked flames or sparks
- ☞ No smoking, no fire!



### Environment!

Use a suitable container to collect the fuel as it drains and dispose of it in an environmentally friendly manner!



### Notice!

Do not run the fuel tank completely dry. Otherwise, air is drawn into the fuel system. This requires bleeding the fuel system – see **Bleeding the fuel system** on page 5-5.



### Notice!

Fill up the tank with the correct fuel type at the end of each working day. This prevents condensation water from forming in the fuel tank over night. Do not fill the tank completely but leave some space for the fuel to expand.



**Stationary fuel pumps**

**General**

Only refuel from stationary fuel pumps. Fuel from barrels or cans is usually dirty. Even the smallest particles of dirt can cause

- Increased engine wear
- Malfunctions in the fuel system and
- Reduced effectiveness of the fuel filters

**Refuelling from barrels**

If refuelling from barrels cannot be avoided, note the following points (see fig. 31):

- Barrels must neither be rolled nor tilted before refuelling
- Protect the suction pipe opening of the barrel pump with a fine-mesh screen
- Immerse it down to a max. 15 cm above the floor of the barrel
- Only fill the tank using refuelling aids (funnels or filler pipes) with integral microfilter
- Keep all refuelling containers clean at all times

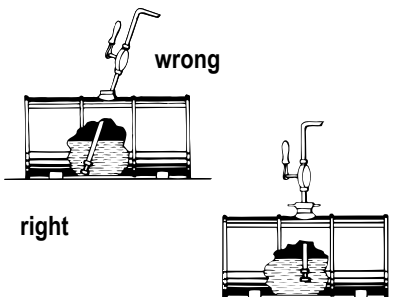


Fig. 31: Refuelling from a barrel

**Diesel fuel specification**

Use only high-grade fuels

Grade	Cetane number	Use
• No. 2-D according to DIN 51601	Min. 45	For normal outside temperatures
• No. 1-D according to DIN 51601		For outside temperatures below 4 °C or for operation above 1500 m altitude

**Bleeding the fuel system**



**Danger!**

If the fuel, as it drains, comes into contact with hot engine parts or the exhaust system, there is an increased

**Danger of burns!**

*Never bleed the fuel system if the engine is hot!*

Bleed the fuel system in the following cases:

- After removing and fitting the fuel filter, prefilter or the fuel lines back on again
- After running the fuel tank empty
- After running the engine again, after it has been out of service for a longer period of time

**Bleed the fuel system as follows:**

- ☞ Fill the fuel tank
- ☞ Turn the ignition key to the first position
- ☞ Wait about 5 minutes while the fuel system bleeds itself automatically
- ☞ Start the engine

If the engine runs smoothly for a while and then stops, or if it does not run smoothly:

- ☞ Stop the engine
- ☞ Bleed the fuel system again as described above
- ☞ Have this checked by authorised staff if necessary

**Fuel prefilter with water separator**

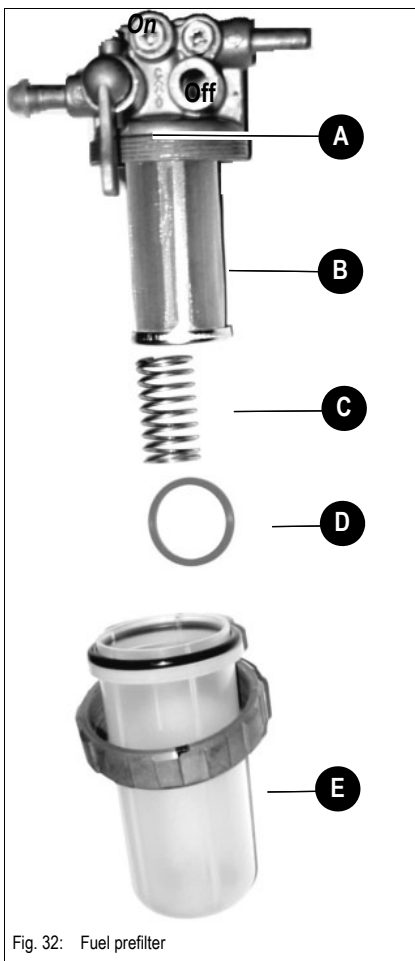


Fig. 32: Fuel prefilter

Check the fuel prefilter as follows:

- If the red indicator ring **D** in sight glass **E** rises
  - ☞ Remove and clean the housing (sight glass)
  - ☞ Remove and clean filter insert **B**
  - ☞ Mount filter insert
  - ☞ Mount the housing (sight glass) with the maintenance display (red ring) and spring **D**
  - ☞ Open stop cock **A**

Interrupt fuel supply as follows:

- ☞ Turn ball-type cock **A** to the **OFF** mark
  - ➔ Fuel supply is interrupted
- ☞ Turn ball-type cock **A** to the **ON** mark
  - ➔ Fuel supply is open again



**Environment!**

Thread **A** is fitted with a hose. Collect the water as it drains with a suitable container and dispose of it in an environmentally friendly manner.

**Replacing the fuel filter****Danger!**

If the fuel, as it drains, comes into contact with hot engine parts or the exhaust system, there is an increased

**Danger of burns!**

☞ *Never change the fuel filter if the engine is hot!*

**Environment!**

Use a suitable container to collect the fuel as it drains and dispose of it in an environmentally friendly manner!

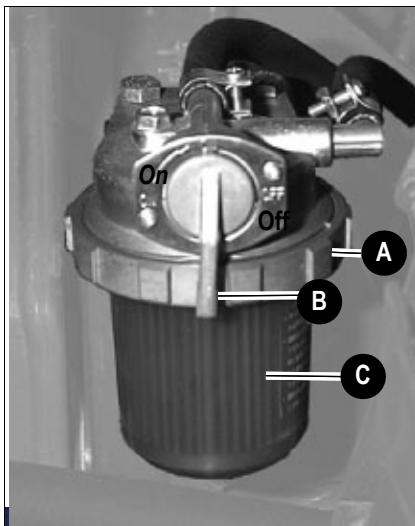


Fig. 33: Fuel filter 1001/1501

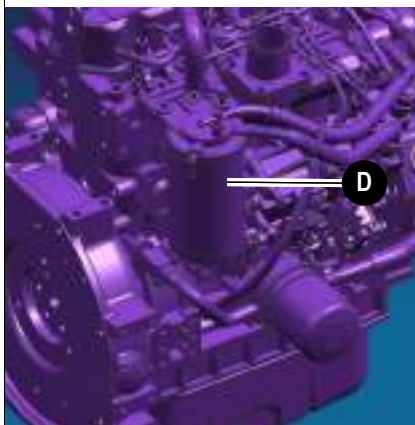


Fig. 33: Fuel filter 2001

**Removing the fuel filter (D)**

- ☞ Close fuel cock **B**
- ☞ Slacken union nut **A**  
*Caution: the filter housing contains fuel*
- ☞ Remove filter housing **C**

**Mounting the fuel filter**

- ☞ Mount all elements in the reverse order with a new filter element
- ☞ Open the stop cock on the water separator again
- ☞ Bleed the fuel system – see **Bleeding the fuel system** on page 5-5
- ☞ Make a test run – and check for tightness!
- ☞ Dispose of the old fuel filter cartridge by an ecologically safe method

## 5.5 Engine lubrication system



### Caution!

If the engine oil level is too low or if an oil change is overdue, this can cause

### Engine damage or loss of output!

- ☞ Have the oil changed by an authorised workshop  
– see chapter 5.16 *Maintenance plan 2001: overview* on page 5-37

### Checking the oil level



### Notice!

Check the oil level once a day.  
We recommend checking it before starting the engine. After stopping a warm engine, wait at least 5 minutes before checking.

### Checking the oil level

- ☞ Proceed as follows:

- Park the machine on level ground
- Stop the engine!
- Let the engine cool down
- Open the engine cover
- Clean the area around the oil dipstick with a lint-free cloth
- Oil dipstick **A**:

- ☞ Pull it out
- ☞ Wipe it with a lint-free cloth
- ☞ Push it back in as far as possible
- ☞ Withdraw it and read off the oil level

- ☞ However if necessary, fill up oil at the latest when the oil reaches the MIN mark on the oil dipstick **A**

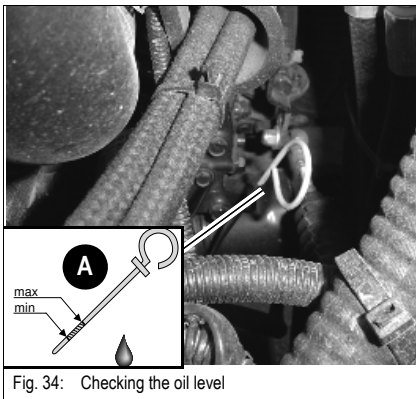


Fig. 34: Checking the oil level

**Filling up engine oil****Caution!**

Too much or incorrect engine oil can result in engine damage! For this reason:

- ☞ Do not add engine oil above the **MAX** mark of oil dipstick 34/A
- ☞ Use only the specified engine oil

**Environment!**

Use a suitable container to collect the engine oil as it drains and dispose of it in an environmentally friendly manner!

**Filling up engine oil**

☞ Proceed as follows:

- Clean the area around oil filler cap **B** with a lint-free cloth
- Open filler cap **B**
- Raise oil dipstick **A** slightly to allow any trapped air to escape
- Fill in engine oil
- Wait about 3 minutes until all the oil has run into the oil sump
- Check the oil level – see **Checking the oil level** on page 5-8
- Fill up if necessary and check the oil level again
- Close filler cap **B**
- Push oil dipstick **A** back in as far as possible
- Completely remove all oil spills from the engine

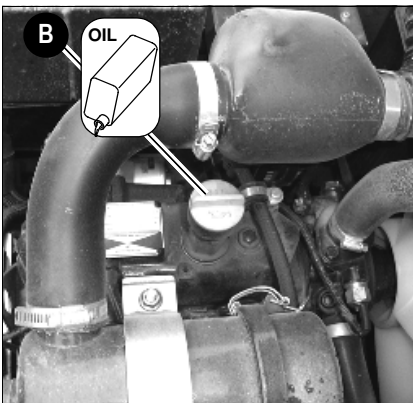


Fig. 35: Filling up engine oil

## 5.6 Engine and hydraulics cooling system

The oil/water radiator is located in the engine compartment, behind the engine. It cools the diesel engine, and the hydraulic oil of the drive and work hydraulics.

The expansion tank for the coolant is located in the engine compartment next to the toolbox.

### Specific safety instructions

- Dirt on the radiator fins reduces the cooler's heat dissipation capacity! To avoid this:
  - ☞ Clean the outside of the radiator at regular intervals. Use oil-free compressed air (2 bar max.) to clean. Maintain a certain distance to the radiator to avoid damage to the radiator fins. Refer to the maintenance plans in the appendix for the cleaning intervals
  - ☞ In dusty or dirty work conditions, clean more frequently than indicated in the maintenance plans
- An insufficient coolant level reduces the heat dissipation capacity as well and can lead to engine damage! Therefore:
  - ☞ Check the coolant level at regular intervals. Refer to the maintenance plans in the appendix for the intervals
  - ☞ If coolant must be added frequently, check the cooling system for leaks and/or contact your dealer!
  - ☞ Never fill in cold water/coolant if the engine is warm!
  - ☞ After filling the expansion tank, make a test run with the engine and check the coolant level again after stopping the engine
- The use of the wrong coolant can destroy the engine and the cooler. Therefore:
  - ☞ Add enough antifreeze compound to the coolant – but never more than 50 %. If possible use brand-name antifreeze compounds with anticorrosion additives
  - ☞ Observe the coolant compound table – see [chapter 6.14 Coolant compound table](#) on page 6-14
  - ☞ Do not use cooler cleaning compounds if an antifreeze compound has been added to the coolant – otherwise this causes sludge to form, which can damage the engine
- Once you have filled the expansion tank:
  - ☞ Test run the engine
  - ☞ Stop the engine
  - ☞ Let the engine cool down
  - ☞ Check the coolant level again



### Environment!

Use a suitable container to collect the coolant as it drains and dispose of it in an environmentally friendly manner!

**Checking/filling up coolant****Danger!**

Never open the coolant tank and never drain coolant if the engine is warm since the cooling system is under high pressure

–

**Danger of burns!**

- ☞ *Wait at least 15 minutes after stopping the engine!*
- ☞ *Wear protective gloves and clothing*
- ☞ *Open filler cap **B** to the first notch and release the pressure*
- ☞ *Make sure the coolant temperature is sufficiently low so you can touch the radiator plug with your hands*

**Danger!**

Antifreeze is flammable and poisonous –

**Danger of accidents!**

- ☞ *Keep away from flames*
- ☞ *Avoid eye contact with antifreeze*
  - *If antifreeze comes into contact with the eyes*
    - ➔ *Immediately rinse with clean water and seek medical assistance*

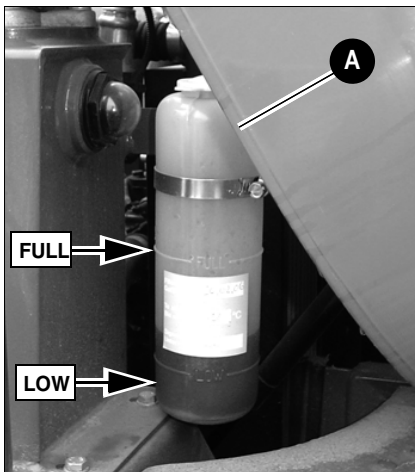


Fig. 36: Expansion tank for coolant

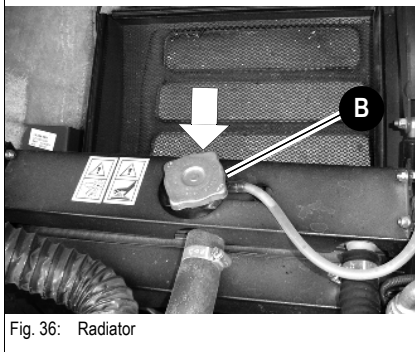


Fig. 36: Radiator

### Checking the coolant level

☞ Proceed as follows:

- Park the machine on level ground
  - Stop the engine!
  - Remove the key and carry it with you
  - Let the engine and the coolant cool down
  - Open the engine cover
  - Check the coolant level on the transparent coolant tank **A** and on the radiator **B**
- ☞ If the coolant level is below the **LOW** seam or if there is no coolant at the radiator's filler inlet:
- Fill up coolant

### **i** Notice!

Check the coolant level once a day.  
We recommend checking it before starting the engine.

### Filling up coolant

After the engine has cooled down:

- ☞ Release overpressure in the radiator
- ☞ Carefully open the cap to the first notch and fully release the pressure
- ☞ Open filler cap **B**
- ☞ Fill in coolant up to the lower edge of the filler inlet (radiator)
- ☞ Close filler cap **B**
- ☞ Start the engine and let it warm up for about 5 – 10 minutes
- ☞ Stop the engine
- ☞ Remove the key and carry it with you
- ☞ Let the engine cool down
- ☞ Check the coolant level again
  - ➔ The coolant level must be between the **LOW** and **FULL** tank seams
- ☞ If necessary, fill up coolant and repeat the procedure until the coolant level remains constant

### **i** Notice!

Check the antifreeze every year before the cold season sets in!



## 5.7 Air filter



### Caution!

The filter cartridge will be damaged if it is washed or brushed out! Bear in mind the following to avoid premature engine wear!

- ☞ Do not clean the filter cartridge
- ☞ Replace the filter cartridge when the telltale comes on
- ☞ Never reuse a damaged filter cartridge
- ☞ Ensure cleanliness when replacing the filter cartridge!

Control element **A** on the air filter monitors the filter cartridge.

☞ Replace filter **B** if:

- Control element **A** indicates air filter contamination
- According to the maintenance plan



### Notice!

For **applications in especially dusty environment**, replace or clean the air filter more frequently.

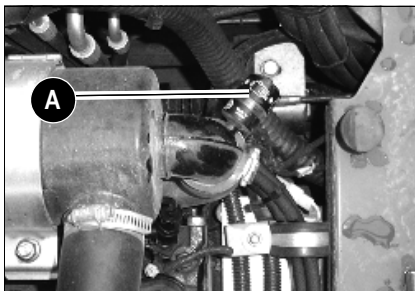


Fig. 37: Indicator for air filter contamination

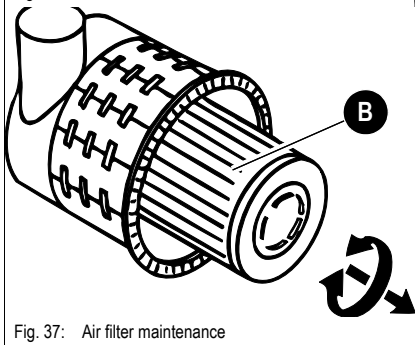


Fig. 37: Air filter maintenance



### Caution!

Filter cartridges degrade prematurely when in service in acidic air for longer periods of time. This risk is present for example in acid production facilities, steel and aluminium mills, chemical plants and other nonferrous-metal plants.

- ☞ Replace filter **B** after 50 service hours at the latest!

General instructions for air filter maintenance:

- Store filters in their original packaging and in a dry place
- Do not knock the filter against other objects as you install it
- Check air filter attachments, air intake hoses and air filters for damage, and immediately repair or replace if necessary
- Check the screws at the induction manifold and the clamps for tightness

## Replacing the filter

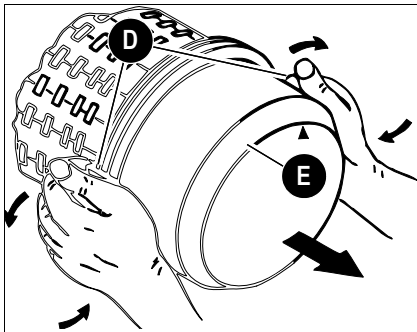


Fig. 38: Removing the lower housing section

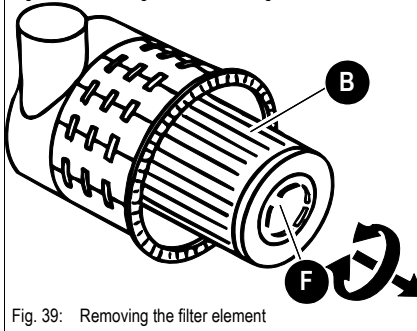


Fig. 39: Removing the filter element

- Replace filter **A** as follows:

- ☞ Stop the engine
- ☞ Remove the key and carry it with you
- ☞ Let the engine cool down
- ☞ Open the engine cover
- ☞ Remove dirt and dust from the air filter and the area around the air filter
- ☞ Fold both bow clips **D** on lower housing section **E** to the outside
- ☞ Remove lower housing section **E**
- ☞ Unscrew wing nut **F**
- ☞ Carefully remove filter **B** with slightly turning movements
- ☞ **Make sure** all dirt (dust) inside the air filter housing has been removed
  - ☞ Clean the parts with a clean lint-free cloth, do not use compressed air
- ☞ Check the air filter cartridges for damage, only install intact filters
- ☞ Carefully insert the new filter **B** in the air filter housing
- ☞ Position lower housing section **E** (make sure it is properly seated)
- ☞ Close both bow clips **D**

## 5.8 V-belt



### Danger!

Only check or retighten/replace the V-belt when the engine is stopped –

#### Danger of personal injury!

- ☞ Stop the engine before carrying out inspection work in the engine compartment!
- ☞ Disconnect the battery
- ☞ Let the engine cool down



### Caution!

Cracked and stretched V-belts cause engine damage

- ☞ Have the V-belt replaced by an authorised workshop

Check the V-belt once a day or every 10 service hours, and retighten if necessary!  
Retighten new V-belts after about 15 minutes of running time.

### Checking V-belt tension

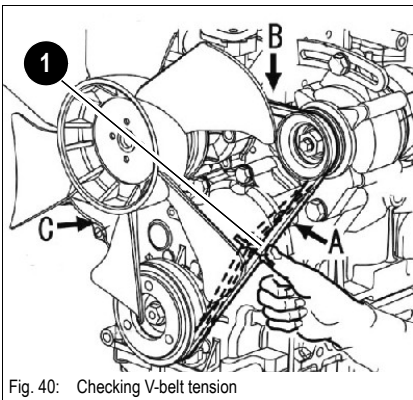


Fig. 40: Checking V-belt tension

- Check as follows:
  - ☞ Stop the engine
  - ☞ Remove the key and carry it with you
  - ☞ Disconnect the battery
  - ☞ Let the engine cool down
  - ☞ Open the engine cover
  - ☞ Carefully check V-belt 1 for damage, cracks or cuts
  - ☞ Replace the V-belt if it touches the base of the V-belt groove or the discs of the pulley
- If the V-belt is damaged:
  - ☞ Have the V-belt replaced by authorised staff
  - ☞ Press with your thumb about 100 N to check the deflection of the V-belt between the crankshaft disc and the fan wheel. A new V-belt should have a deflection of 6 to 8 mm, a used V-belt (after about 5 minutes running time) should have a deflection of 7 to 9 mm.
  - ☞ Retighten the V-belt if necessary

## Retightening the V-belt



### Caution!

Overtightening the V-belt can damage the V-belt, the V-belt guide and the water pump bearing.

Avoid contact of oil, grease or similar substances with the V-belt.

☞ Check V-belt tension – see **Checking V-belt tension** on page 5-15

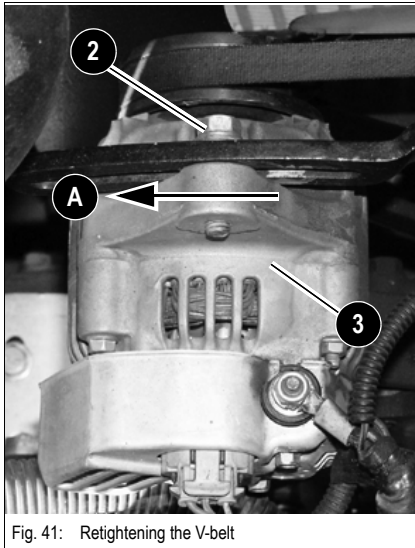


Fig. 41: Retightening the V-belt

- Retighten as follows:
  - ☞ Stop the engine
  - ☞ Fold the control lever base up
  - ☞ Remove the key and carry it with you
  - ☞ Disconnect the battery or the battery master switch
  - ☞ Let the engine cool down
  - ☞ Open the engine cover
  - ☞ Slacken fastening screws **2** of alternator **3**
  - ☞ Use a suitable tool to push the alternator in the direction of arrow **A** until reaching the correct V-belt tension (fig. 41)
  - ☞ Keep the alternator in this position, and at the same time retighten fastening screws **2**
  - ☞ Check V-belt tension again and adjust it if necessary
  - ☞ Connect the battery or the battery master switch
  - ☞ Close the engine cover

## 5.9 Hydraulic system

### Specific safety instructions



- Release the pressure in all lines carrying hydraulic oil prior to any maintenance and repair work. To do this:
  - Lower all hydraulically controlled attachments
  - Move all control levers of the hydraulic control valves several times
- Hydraulic oil escaping under high pressure can penetrate the skin and cause serious injuries. Always consult a doctor immediately even if the wound seems insignificant – otherwise serious infections could set in!
- If the hydraulic oil in the sight glass is cloudy, this indicates that water or air has penetrated the hydraulic system. This can cause damage to the hydraulic pump!
- Oil or fuel flowing out of high pressure lines can cause fire or malfunctions, and severe injuries or damage to property. Interrupt work immediately if slack nuts or damaged hoses and lines are detected.
  - ☞ Contact your Wacker Neuson dealer immediately
- Replace the hose or line if one of the problems mentioned below is detected.
  - ☞ Damaged or leaky hydraulic seals.
  - ☞ Worn or torn shells or uncovered reinforcement branches.
  - ☞ Expanded shells in several positions.
  - ☞ Entangled or crushed movable parts.
  - ☞ Foreign bodies jammed or stuck in protective layers.



### Caution!

Dirty hydraulic oil, lack of oil or wrong hydraulic oil –

#### **Danger of severe damage to the hydraulic system!**

- ☞ Take care to avoid contamination when working!
- ☞ Always fill in hydraulic oil using the filling screen!
- ☞ Only use authorised oils of the same type
  - see [chapter 5.13 Engine/machine fluids and lubricants \(1001 and 1501\)](#) on page 5-30
- ☞ Always fill up hydraulic oil before the level gets too low
  - see [Filling up hydraulic oil](#) on page 5-19
- ☞ If the hydraulic system is filled with biodegradable oil, then only use biodegradable oil of the same type for filling up – observe the sticker on the hydraulic oil tank!
- ☞ Contact customer service if the hydraulic system filter is contaminated with metal chippings. Otherwise, follow-on damage can result!



### Environment!

Collect drained hydraulic oil and biodegradable oil in a suitable container!  
Dispose of drained oil and used filters by an ecologically safe method.  
Always contact the relevant authorities or commercial establishments in charge of oil disposal before disposing of biodegradable oil.

Checking the hydraulic oil level



**Caution!**

Do not fill up oil if the oil level is above the **FULL** mark, otherwise the hydraulic system can be damaged and escaping oil can cause serious injuries.

☞ Check the hydraulic oil level each time the machine is put into operation or once a day

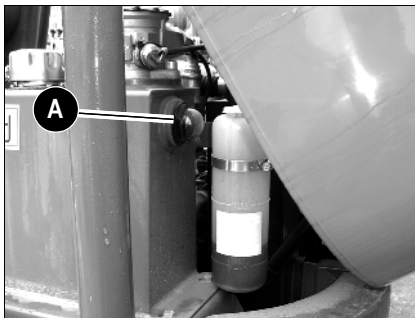


Fig. 42: Oil level indicator on the hydraulic oil tank 1001/

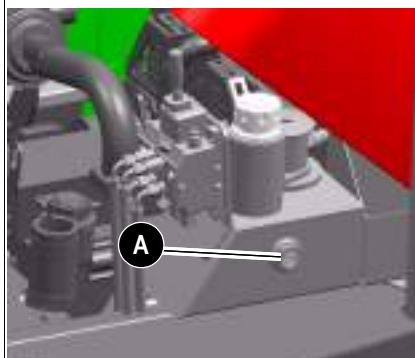


Fig. 42: Oil level indicator on the hydraulic oil tank 2001

☞ Proceed as follows:

- Park the machine on level ground
- Retract all hydraulic rams
- ☞ Fully dump in the skip
- Stop the engine
- Sight glass **A** is under the engine cover behind the hydraulic oil tank
- Check the oil level on sight glass **A**
- The oil level must be at the **FULL** level
  - A gauge element in sight glass **A** indicates the oil level

If the oil level is lower

- Fill up hydraulic oil

The oil level varies according to the machine's operating temperature:

Machine condition	Temperature	Oil level
• Before putting into operation	Between 10 and 30 °C	<b>LOW</b> mark
• Normal operation	Between 50 and 90 °C	<b>FULL</b> mark



**Notice!**

Measure the oil level of the hydraulic system only after the machine reaches its operating temperature.

**Filling up hydraulic oil****Danger!**

Removing the filler plug can cause oil to escape –

**Danger of accidents!**

☞ *Carefully unscrew the plug to slowly reduce the pressure inside the tank.*

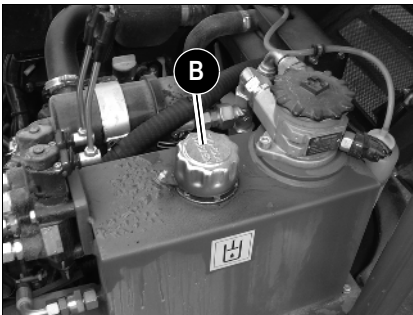


Fig. 43: Hydraulic oil tank

Do not fill up the hydraulic oil unless the engine is stopped. Otherwise, hydraulic oil will overflow at the filler opening on the hydraulic tank.

☞ *Fill up as follows:*

- Park the machine on level ground
- Retract all hydraulic rams
- Stop the engine
- Clean the area around filler inlet **B** with a cloth
- Open filler inlet **B**

With the filter insert in place:

- Fill up hydraulic oil
- Check the hydraulic oil level on sight glass **A**
- Fill up if necessary and check again
- Firmly tighten plug **B**

Changing hydraulic oil

**i Notice!**

Only change the hydraulic oil if it is warm (about 50 °C).  
Lower the skip in centre position before draining the oil (dumper in straight-ahead position).

- ☞ Open the drain plug to let the oil drain into a container
- ☞ Check the hydraulic oil tank for contamination and clean if necessary
- ☞ Replace the filter according to the maintenance specifications
- ☞ Screw the drain plug back in correctly
- ☞ Fill in clean hydraulic oil through the screen  
– see **Filling up hydraulic oil** on page 5-19
- ☞ Close the hydraulic oil tank correctly
- ☞ Let the machine run at idling speed without load for some minutes

Fouling indicator for hydraulic oil filter

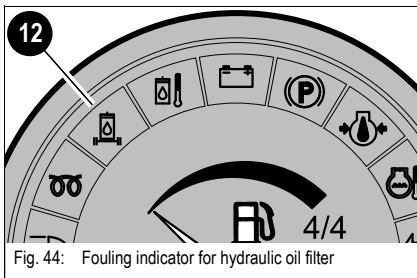


Fig. 44: Fouling indicator for hydraulic oil filter

A red telltale on the instrument panel monitors the filter.

Replace the filter:

- If the telltale comes on when the hydraulic oil is at operating temperature
- According to the maintenance interval

In cold weather the telltale can come on immediately when the engine is started. This is caused by increased oil viscosity. In this case:

- ☞ Let the engine run at idling speed for about 2 minutes

Replacing the hydraulic oil filter element

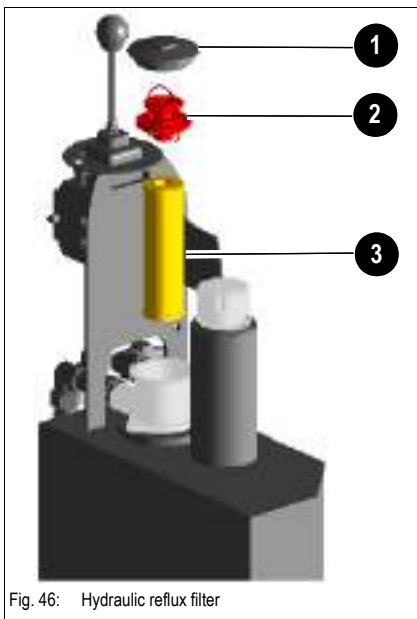


Fig. 46: Hydraulic reflux filter

Proceed as follows:

- ☞ Stop the engine
- ☞ Open cover **1** by about 2 turns and wait until the oil level in the filter housing drops to the oil level in the hydraulic oil tank
- ☞ Open the cover completely and remove it
- ☞ Pull filler pipe **2** upwards with a slightly turning movement, together with filter element **3**
- ☞ Remove the filter element from the filler pipe and dispose of it
- ☞ Slide the filler pipe onto the new filter element and insert it in the filter
- ☞ Tighten the cover by hand





### Important information for the use of biodegradable oil

- Use only the biodegradable hydraulic fluids which have been tested and approved by Wacker Neuson GmbH. Always contact Wacker Neuson GmbH for the use of other products which have not been recommended. In addition, ask the oil supplier for a written declaration of guarantee. This guarantee is applicable to damage occurring on the hydraulic components, which can be proved to be due to the hydraulic fluid.
- Use only biodegradable oil of the same type for filling up. In order to avoid misunderstandings, a label providing clear information is located on the hydraulic oil tank (next to the filler inlet) regarding the type of oil currently used!  
The joint use of two different biodegradable oils can affect the quality of one of the oil types. Therefore, make sure the remaining amount of initial hydraulic fluid in the hydraulic system does not exceed 8 % when changing biodegradable oil (manufacturer indications).
- Do not fill up with mineral oil – the content of mineral oil should not exceed 2 % in order to avoid foaming problems and to ensure biological degradability.
- When running the machine with biodegradable oil, the same oil and filter replacement intervals are valid as for mineral oil – see [chapter 5.16 Maintenance plan 2001: overview](#) on page 5-37.
- Always have the condensation water in the hydraulic oil tank drained by an authorised workshop before the cold season. The water content may not exceed 0.1 % by weight.
- The instructions in this Operator's Manual concerning environmental protection are also valid for the use of biodegradable oil.
- If additional hydraulic attachments are mounted or operated, use the same type of biodegradable oil for these attachments to avoid mixtures in the hydraulic system.

Subsequent change from mineral oil to biodegradable oil must be carried out by an authorised workshop or by your Wacker Neuson partner

## Checking hydraulic pressure lines

### Specific safety instructions

---



#### **Danger!**

Caution when checking hydraulic lines, especially when searching for leaks. Hydraulic oil escaping under high pressure can penetrate the skin and cause serious injuries.

#### **Danger of personal injury!**

- ☞ *Always consult a doctor immediately, even if the wound seems insignificant – otherwise serious infections could set in!*
- ☞ *Always observe the following instructions:*
  - Retighten leaking screwed fittings and hose connections only when the system is not under pressure; i.e. release the pressure before working on pressurised lines!
  - Never weld or solder damaged or leaking pressure lines and screw connections. Replace damaged parts with new ones!
  - Never search for leaks with your bare hands, but wear protective gloves!
  - Use paper or wood to check for minor leaks. Never use an unprotected light or naked flame!
  - Have damaged flexible lines replaced by authorised workshops only!

- 
- Leaks and damaged pressure lines must be immediately repaired or replaced by an authorised workshop or after-sales staff.  
This not only increases the operating safety of your machine but also helps to protect the environment.
  - Replace hydraulic hoses every 6 years from the date of manufacture, even if they do not seem to be damaged.

In this respect, we recommend that you observe all the relevant safety regulations for hydraulic lines, as well as the safety regulations regarding accident prevention and occupational health and safety in your country. Also observe DIN 20066, part 5.

## 5.10 Tyres



Fig. 47: Tyres

Tyre wear can vary according to work and ground conditions.



### **Danger!**

Improper tyre repairs –

### **Danger of accidents!**

☞ *All repair work on tyres and rims may only be carried out by authorised workshops.*

☞ *We recommend checking the tyres for wear and the wheel nuts for tightness once a day.*

☞ *Park the machine on firm and level ground to check and carry out maintenance.*



### **Notice!**

Checking the tyres at regular intervals increases operational safety and the service life of the tyres, and reduces machine downtimes. Please refer to [Chapter 6.12 "Tyres"](#) for the authorised tyre types and the correct tyre pressures.



### **Notice!**

Replace tyres with new ones after 6 years (irrespective of wear) and dispose of them correctly. After this period, the rubber no longer has its full capability due to various chemical and physical processes.

### **Inspection work**

☞ *Carry out the following maintenance work once a day:*

- Visual check of the tyre condition
- Check the tyre pressure
- Tyre and rim (outside and inside) for damage
- Check for wear
- Remove foreign bodies from the tyre tread
- Remove traces of oil and grease from the tyres

## Wheel change



### Caution!

The wheels are heavy and can damage the threads on the wheel studs if they are handled incorrectly!

- ☞ Use suitable assembly tools, such as covering sleeves for the studs, a jack etc.

### Removing

Proceed as follows:

- ☞ Park the machine on level and firm ground and prevent it from rolling away
- ☞ Slightly loosen the wheel nuts of the wheel you want to remove
- ☞ Place a jack under the axle body, making sure it is standing firmly
- ☞ Raise the side of the axle from which you want to remove the wheel
- ☞ Check the machine is standing firmly
- ☞ Completely remove the wheel nuts
- ☞ Remove the wheel

### Fitting the wheels

Proceed as follows:

- ☞ Place the wheel onto the wheel studs
- ☞ Tighten all wheel nuts part-way
- ☞ Lower the raised axle
- ☞ Tighten the wheel nuts to the prescribed torque of **125 Nm**



### Notice!

Subsequent to changing wheels check the wheel nuts for tightness after 10 service hours – tighten if necessary!

## 5.11 Electrical system

### Specific safety instructions



- The battery contains sulphuric acid! This acid must not be allowed to come into contact with the skin, the eyes, clothing or the machine.

Therefore when recharging or working near the battery:

- ☞ Always wear goggles and protective clothing with long sleeves

If acid is spilt:

- ☞ Thoroughly rinse all affected surfaces immediately with plenty of water
- ☞ Thoroughly wash any part of the body touched by the acid immediately with plenty of water and seek medical attention at once!

- Especially when charging batteries, as well as during normal operation of batteries, an oxyhydrogen mixture is formed in the battery cells – danger of explosion!
- Do not attempt to jump-start the machine if the battery is frozen or if the acid level is low. The battery can rupture or explode!
  - ☞ Replace the battery immediately
- Avoid naked flames and sparks and do not smoke in the vicinity of open battery cells – otherwise the gas produced during normal battery operation can ignite!
- Use only 12 V power sources. Higher voltages will damage the electric components
- When connecting the battery leads, make sure the poles +/- are not inverted, otherwise sensitive electric components will be damaged
- Do not interrupt voltage-carrying circuits at the battery terminals because of the danger of sparking!
- Never place tools or other conductive articles on the battery – danger of short circuit!
- Disconnect the negative (-) battery terminal from the battery before starting repair work on the electrical system
- Dispose of used batteries properly

### Service and maintenance work at regular intervals

#### Before driving the machine

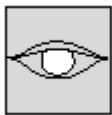
☞ Check every time before driving the machine:

- Is the light system OK?
- Is the signalling and warning system OK?

#### Every week

☞ Check once a week:

- Cable and earth connections
- Battery charge condition – see **Battery** on page 5-27
- Condition of battery terminals





## Instructions concerning specific components

### Cables, bulbs and fuses

#### Always observe the following instructions:

- Defective components of the electrical system must always be replaced by an authorised expert. Bulbs and fuses may be changed by unqualified persons
- When carrying out maintenance work on the electrical system, pay particular attention to ensuring good contact in leads

## Alternator

#### Always observe the following instructions:

- Only test run the engine with the battery connected
- When connecting the battery, make sure the poles (+/-) are not inverted
- Always disconnect the battery before carrying out welding work or connecting a quick battery charger

**Battery****Danger!**

Battery acid is highly caustic!

**Danger of caustic injury!**

Therefore when recharging and/or working near the battery:

☞ *Always wear goggles and protective clothing with long sleeves*

If acid is spilt:

☞ *Thoroughly rinse all affected surfaces immediately with plenty of water*

☞ *Thoroughly wash any part of the body touched by the acid immediately with plenty of water and seek medical attention at once!*

Especially when charging batteries, as well as during normal operation of batteries, an oxyhydrogen mixture is formed in the battery cells –

**Danger of explosion!**

☞ *Avoid naked lights and sparks in the vicinity of the battery and do not smoke!*

☞ *Do not attempt to jump-start the machine if the battery is frozen or if the acid level is low. The battery can rupture or explode!*

- Replace the battery immediately

☞ *Always disconnect the negative terminal (–) from the battery before starting repair work on the electrical system!*

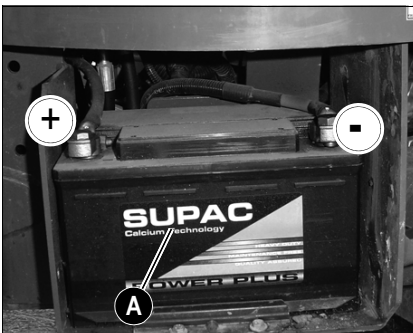


Fig. 48: Battery

Battery **A** is located underneath the engine cover. The battery is “maintenance-free”. However have the battery checked at regular intervals to make sure the electrolyte level is between the MIN and MAX marks.

Checking the battery requires it to be removed and must be carried out by an authorised workshop.

Always follow the specific battery safety instructions!

**Notice!**

Do not disconnect the battery while the engine is running.

## 5.12 General maintenance work

### Cleaning

Cleaning the machine is divided into 2 separate areas:

- Exterior of the machine
- Engine compartment

The wrong choice of cleaning equipment and agents can impair the operating safety of the machine on the one hand, and on the other undermine the health of the persons in charge of cleaning the machine. It is therefore essential to observe the following instructions.

### General instructions for all areas of the machine

#### Cleaning with washing solvents

- Ensure adequate room ventilation
- Wear suitable protective clothing
- Do not use flammable liquids, such as petrol or diesel

#### Cleaning with compressed air

- Work carefully
- Wear goggles and protective clothing
- Do not aim the compressed air at the skin or at other people
- Do not use compressed air for cleaning your clothing

#### Cleaning with a high-pressure cleaner or steam jet

- Electric components and damping material must be covered and not directly exposed to the jet
- Cover the vent filter on the hydraulic oil tank and the filler caps for fuel, hydraulic oil etc.
- Protect the following components from moisture:
  - Engine
  - Electric components such as the alternator etc.
  - Control devices and seals
  - Air intake filters etc.

#### Cleaning with volatile and easily flammable anticorrosion agents and sprays:

- Ensure adequate room ventilation
- Do not use unprotected lights or naked flames
- Do not smoke!



**Exterior of the machine****Caution!**

Cleaning the machine can cause engine damage.

☞ *Protect the engine against humidity*

The following articles are generally suitable:

- High-pressure cleaner
- Steam jet

**Engine compartment****Danger!**

Clean the engine at engine standstill only –

**Danger of personal injury!**

☞ *Stop the engine before cleaning*

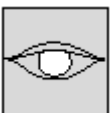
**Caution!**

When cleaning the engine with a water or steam jet

☞ *The engine must be cold*

☞ *and do not point the jet directly at electric sensors such as the oil pressure switch.*

The humidity penetrating any such sensors causes them to fail and leads to engine damage!

**Screw connections and attachments**

All screw connections must be checked regularly for tightness, even if they are not listed in the maintenance schedules.

☞ *Engine fastening screws*

☞ *Fastening screws on the hydraulic system*

☞ *Line and pin fastenings on the attachment*

Retighten loose connections immediately. Contact an authorised workshop if necessary.

**Pivots and hinges**

Lubricate all mechanical pivots on the machine (such as joints) and fittings at regular intervals even if they are not listed in the lubrication plan.

### 5.13 Engine/machine fluids and lubricants (1001 and 1501)

Component/ application	Engine/machine fluid	Specification	Season/tempera- ture	Capacities <sup>1</sup>
Diesel engine	Engine oil	API CD, CF, CF-4, CI-4	- 20 °C +40 °C	3.4 l
		ACEA: E3, E4, E5 (SAE 10W40) <sup>2</sup>		
Hydraulic oil tank	Hydraulic oil	HVLP46 <sup>3</sup>	Year-round	20 l
	Biodegradable oil <sup>4</sup>	PANOLIN HLP Synth 46		
		FINA BIOHYDRAN SE 46 BP BIOHYD SE-46		
Grease nipples	Multipurpose grease <sup>5</sup>	FINA Energrease L21 M	Year-round	As required
Battery terminals	Acid-proof grease <sup>6</sup>	FINA Marson L2	Year-round	As required
Fuel tank	Diesel fuel	2-D ASTM D975 – 94 (USA)	Summer or winter diesel depending on outside tem- peratures	15 l
		1-D ASTM D975 – 94 (USA)		
		EN 590 : 96 (EU)		
		ISO 8217 DMX (International)		
		BS 2869 – A1 (GB)		
		BS 2869 – A2 (GB)		
Radiator	Coolant	Soft water + antifreeze ASTM D4985	Year-round	4 l
		Distilled water + antifreeze ASTM D4985		

1. The capacities indicated are approximative values; the oil level check alone is relevant for the correct oil level  
Capacities indicated are no system fills
2. According to DIN 51511
3. According to DIN 51524 section 3
4. Hydraulic ester oils (HEES)
5. KF2K-25 according to DIN 51502 multipurpose lithium grease with MoS<sup>2</sup> additive
6. Standard acid-proof grease



**Oil grades for the diesel engine, depending on temperature**

Engine oil grade	Ambient temperature (C°)													
	°C	-20	-15	-10	-5	0	5	10	15	20	25	30	35	40
	SAE 10W													
	SAE 20W													
	SAE 10W-30													
	SAE 10W-40													
	SAE 15W-40													
API CD, CF, CF-4, CI-4 ACEA: E3, E4, E5	SAE 20													
	SAE 30													
	SAE 40													
	°F	-4	5	14	23	32	41	50	59	68	77	86	95	104

### 5.14 Engine/machine fluids and lubricants (2001)

Component/ application	Engine/machine fluid	Specification	Season/temperature	Capacities <sup>1</sup>
Diesel engine	Engine oil	Q8 T660, SAE10W-40 <sup>2</sup>	-20 °C +40 °C	5.25 l
Hydraulic oil tank	Hydraulic oil	HVLP46 <sup>3</sup>	Year-round	48 l
	Biodegradable oil <sup>4</sup>	PANOLIN HLP Synth 46		
		FINA BIOHYDRAN SE 46 BP BIOHYD SE-46		
All lubrication points		FINA Energrease L21M	Year-round	As required
Battery terminals	Acid-proof grease <sup>5</sup>	FINA Marson L2	Year-round	As required
Fuel tank	Diesel fuel	2-D ASTM D975 – 94 (USA)	Summer or winter diesel depending on outside tem- peratures	40 l
		1-D ASTM D975 – 94 (USA)		
		EN 590 : 96 (EU)		
		ISO 8217 DMX (International)		
		BS 2869 – A1 (GB)		
		BS 2869 – A2 (GB)		
Radiator	Coolant	Soft water + antifreeze ASTM D4985	Year-round	8.5 l
		Distilled water + antifreeze ASTM D4985		



1. The capacities indicated are approximative values; the oil level check alone is relevant for the correct oil level
2. As per DIN 51502; API CH4, CE/SJ; ACEA A3, B3, E3
3. According to DIN 51524 section 3
4. Hydraulic ester oils (HEES)
5. Standard acid-proof grease
5. First replacement after 50 service hours




Oil grades for the diesel engine, depending on temperature

Engine oil grade	Ambient temperature (C°)															
	°C	-20	-15	-10	-5	0	5	10	15	20	25	30	35	40		
API: CH4, CE/SJ ACEA: A3, B3, E3		SAE 10W														
			SAE 20W													
		SAE 10W-30														
		SAE 10W-40														
		SAE 15W-40														
							SAE 20									
								SAE 30								
										SAE 40						



Work description	Maintenance plan/service hours (s/h)					Maintenance work (once a day)
	Every 50 s/h	Every 500 s/h	Every 1000 s/h once a year	Customer	Authorised workshop	
<b>5.15 Maintenance plan 1001 – 1501: overview</b>						
<b>Work description</b>						
For service and maintenance work on the attachment, please refer to the operation and maintenance manual of the attachment manufacturer as well.						
<b>Fluid and filter changes (  ):</b>						
Carry out the following oil and filter changes (check oil levels after test run):						
• Engine oil <sup>1</sup>	•	•	•		•	•
• Engine oil filter <sup>2</sup>	•	•			•	•
• Fuel filter <sup>3</sup>	•	•			•	•
• Air filter element if fouling indicator is at "Service"				•		
• Coolant			•		•	•
• Hydraulic oil filter insert <sup>4</sup>	•				•	•
• Hydraulic oil <sup>5</sup>		•	•		•	•
<b>Inspection work (  ):</b>						
Check the following material. Refill if necessary:						
• Engine oil					•	•
• Engine coolant					•	•
• Hydraulic oil					•	•
Clean water ducts <sup>6</sup>			•			•
Check radiator for engine and hydraulic oil for dirt. Clean if necessary					•	
Check cooling systems, heating and hoses for leaks and pressure (visual check)					•	
Check the pilot control filter on the main valve block for dirt, clean it if necessary <sup>7</sup>			•			
Air filter (damage)					•	
Prefilter with water separator: drain water					•	
• Clean					•	
Check V-belt condition and tension					•	
Check exhaust system for damage and condition					•	
Check valve clearance. Adjust if necessary						•

5.15 Maintenance plan 1001 – 1501: overview	Maintenance plan/service hours (s/h)					
	Maintenance work (once a day)	Every 50 s/h	Every 500 s/h	Every 1000 s/h once a year	Customer	Authorised workshop
<b>Work description</b> For service and maintenance work on the attachment, please refer to the operation and maintenance manual of the attachment manufacturer as well.						
Clean and adjust the fuel injection pump <sup>8</sup>				●		●
Check and adjust the injection pressure of the injection nozzles, clean the injection needles/nozzles				●		●
Check and adjust injection time <sup>9</sup>					●	●
Empty diesel fuel tank <sup>10</sup>			●			●
Check battery electrolyte. Fill up with distilled water if necessary		●	●		●	●
Check alternator, starter and electric connections, bearing play and function			●			●
Check preheating system and electric connections			●			●
Pressure check of primary pressure limiting valves <sup>11</sup>		●	●			●
Check tracks for cracks and cuts	●				●	
Check track tension. Retighten if necessary	●				●	
Check bearing play of tread rollers, track carrier rollers, front idlers			●			●
Check piston rods for damage					●	
Check screws for tightness <sup>8</sup>		●	●			●
Check pin lock	●				●	
Check line fixtures	●				●	
Check telltales for correct function		●	●			●
Couplings, dirt pile-up on hydraulic system dust caps if necessary					●	
Check insulating mats in the engine compartment for damage/condition		●			●	
Check labels and Operator's Manual for completeness and condition		●			●	
<b>Lubrication service</b> (  ):						
Lubricate the following assemblies/components (all grease nipples):						
• Stabiliser blade	●					●
• Swivelling console	●					●

Work description	Maintenance plan/service hours (s/h)					Authorised workshop
	Maintenance work (once a day)	Every 50 s/h	Every 500 s/h	Every 1000 s/h once a year	Customer	
<b>5.15 Maintenance plan 1001 – 1501: overview</b> <b>Work description</b> For service and maintenance work on the attachment, please refer to the operation and maintenance manual of the attachment manufacturer as well.	• Loader unit	•				
	• Attachments	•			•	
	• Grease strip on chassis	•				•
<b>Functional check (  ):</b> Check the function of the following assemblies/components. Rectify if necessary:						
• Lights, signalling system, acoustic warning system <sup>12</sup>		•	•			•
<b>Leakage check (  ):</b> Check for tightness, leaks and chafing: pipes, flexible lines and screw connections of the following assemblies and components. Rectify if necessary:						
• Visual check	•				•	
Engine, hydraulic system and hydraulic components	•				•	
Cooling circuit	•				•	
Travelling drive	•				•	

1. Drain engine oil the first time after 50 s/h, then every 250 s/h
2. Replace the engine oil filter the first time after 50 s/h, then every 250 s/h
3. Replace the fuel filter the first time after 50 s/h, then every 500 s/h
4. Replace the hydraulic oil filter insert the first time after 50 s/h, then every 500 s/h
5. Replace the hydraulic oil the first time after 500 s/h, then every 1000 s/h
6. Clean the water ducts every other 1000 s/h servicing
7. Coarse dirt causes malfunctions and can even destroy the filter screen!
8. Clean and adjust the fuel injection pump every other 1000 s/h servicing
9. Check and adjust the fuel injection time every other 1000 s/h servicing
10. Empty the fuel tank every 250 s/h
11. First check after 50 s/h, then every 500 s/h
12. Check the first time at 50 s/h, then every 500 s/h



<b>5.16 Maintenance plan 2001: overview</b>	<b>Work description</b>	<b>Maintenance plan/service hours (s/h)</b>								<b>Authorised workshop</b>		
		Maintenance work (once a day)	Every 50 s/h	Every 250 s/h	Every 500 s/h	Once a year or after 1000 s/h	After 1500 s/h	Customer				
		<b>Fluid and filter changes (  ):</b> Carry out the following oil and filter changes (check oil levels after test run): <ul style="list-style-type: none"> <li>• Engine oil<sup>1</sup></li> <li>• Engine oil filter.<sup>2</sup></li> <li>• Fuel filter.<sup>3</sup></li> <li>• Air filter element</li> <li>• Coolant</li> <li>• Hydraulic oil filter insert<sup>4</sup></li> <li>• Hydraulic oil</li> <li>• Hydraulic oil tank breather</li> </ul>										•
				•	•							•
				•	•							•
				•		•						•
						•						•
				•		•						•
				•					•			
									•			
									•			
									•			
<b>Inspection work (  ):</b>												
Check the following material. Refill if necessary:												
	• Engine oil									•		
	• Engine coolant									•		
	• Hydraulic oil									•		
	Clean the water ducts <sup>5</sup>									•		
	Check radiator for engine and hydraulic oil for dirt. Clean if necessary									•		
	Check cooling systems, heating and hoses for leaks and pressure (visual check)									•		
	Air filter (damage)									•		
	Check the air filter, clean if necessary									•		
	Prefilter with water separator: drain water									•		
	• Clean									•		
	Check V-belt condition and tension									•		







1. Drain engine oil the first time after 50 s/h, then every 250 s/h  
 2. Replace the engine oil filter the first time after 50 s/h, then every 250 s/h  
 3. Replace the fuel filter the first time after 50 s/h, then every 250 s/h  
 4. Replace the hydraulic oil filter insert the first time after 50 s/h, then every 500 s/h  
 5. Clean the water ducts every other 1000 s/h servicing



5.16 Maintenance plan 2001: overview	Maintenance plan/service hours (s/h)							
	Maintenance work (once a day)	Every 50 s/h	Every 250 s/h	Every 500 s/h	Once a year or after 1000 s/h	After 1500 s/h	Customer	Authorised workshop
<b>Work description</b>								
For service and maintenance work on the attachment, please refer to the operation and maintenance manual of the attachment manufacturer as well.								
Check V-belt condition and tension	●						●	●
Check exhaust system for damage and condition	●						●	
Check valve clearance, adjust if necessary					●			●
Fuel injection pump						●		●
Injection and pressure					●			●
Check injection nozzles and valves <sup>1</sup>						●		●
Empty diesel fuel tank				●				●
Check battery electrolyte. Fill up with distilled water if necessary		●		●			●	
Tyre check (damage, air pressure, tread depth)	●						●	
Wheel nuts		●					●	
Check alternator, starter and electric connections, bearing play and function				●				●
Preheating system, electric connections				●				●
Pressure check of primary pressure limiting valves <sup>2</sup>		●		●				●
Check piston rods for damage	●						●	
Check screws for tightness		●		●				●
Pin lock	●						●	
Line fixtures	●						●	
Check telltales for correct function		●		●				●
Insulating mats in engine compartment		●		●				●
Cleanliness of access								
Adhesive labels and Operator's Manual	●						●	●
Engine cover gas strut	●						●	●

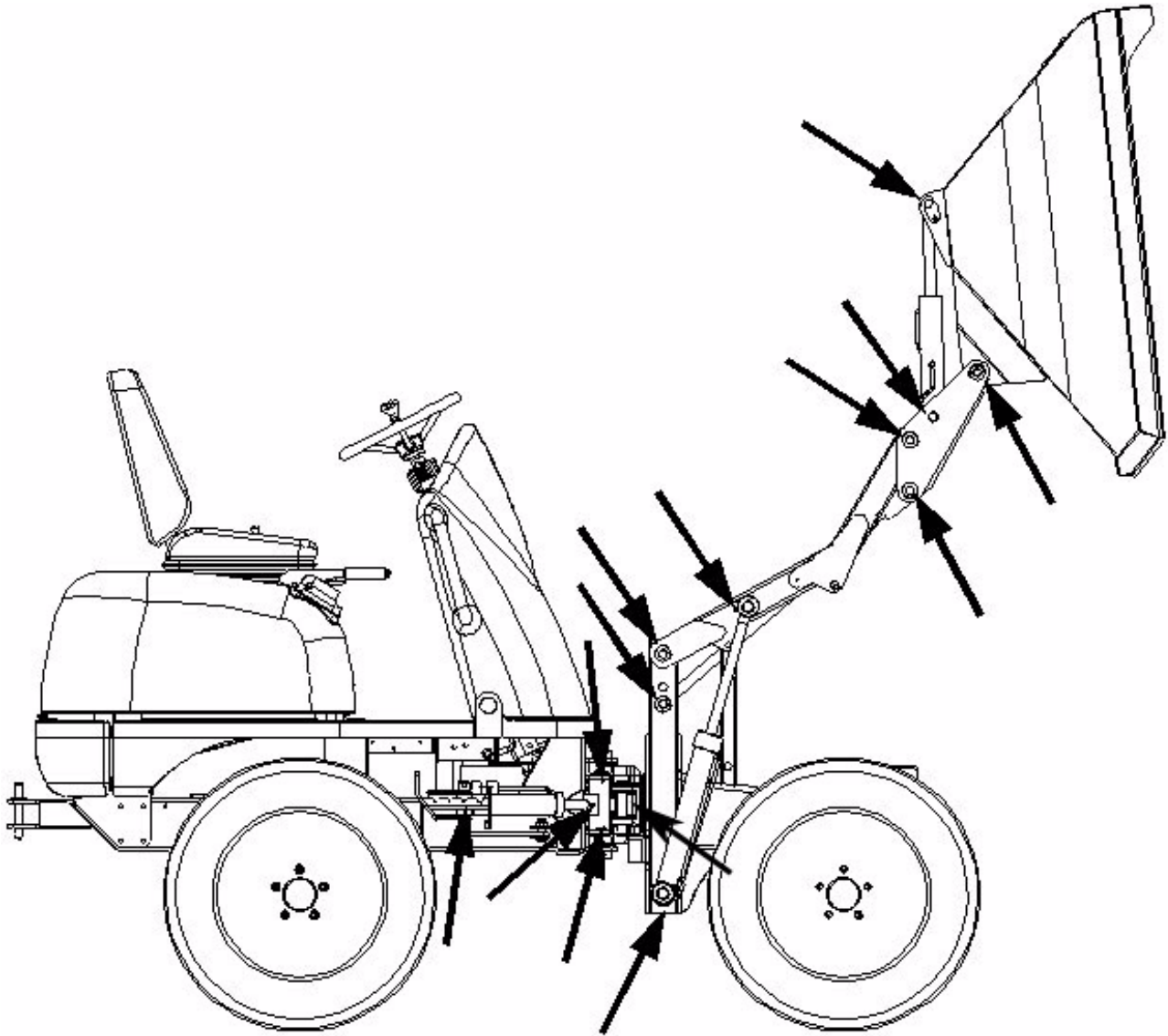
1. Check injection nozzles and valves every second time 1500 s/h servicing is carried out

2. First check at 50 s/h, then every 500 s/h

<b>5.16 Maintenance plan 2001: overview</b>  <b>Work description</b> For service and maintenance work on the attachment, please refer to the operation and maintenance manual of the attachment manufacturer as well.  <b>Lubrication service (  ):</b> Lubricate the following assemblies/components – see <i>Schmierstellenplan</i> on page 3-27: <ul style="list-style-type: none"> <li>• Steering ram</li> <li>• Offset ram</li> <li>• Articulated joint</li> <li>• Swivelling console</li> </ul> <b>Functional check (  ):</b> Check the function of the following assemblies/components. Rectify if necessary: <ul style="list-style-type: none"> <li>• Lights, signalling system, acoustic warning system</li> <li>• Parking brake function</li> <li>• Steering function</li> </ul> <b>Leakage check (  ):</b> Check for tightness, leaks and chafing: pipes, flexible lines and screw connections of the following assemblies and components. Rectify if necessary: <ul style="list-style-type: none"> <li>• Visual check</li> <li> Engine and hydraulic system</li> <li> Cooling circuit</li> <li> Travelling drive</li> </ul>	Maintenance work (once a day)	Every 50 s/h	Every 250 s/h	Every 500 s/h	Once a year or after 1000 s/h	After 1500 s/h	Customer	Authorised workshop	
		●						●	
		●						●	
		●						●	
		●						●	
			●						●
									●
									●

## 5.17 Lubrication points 1001: overview

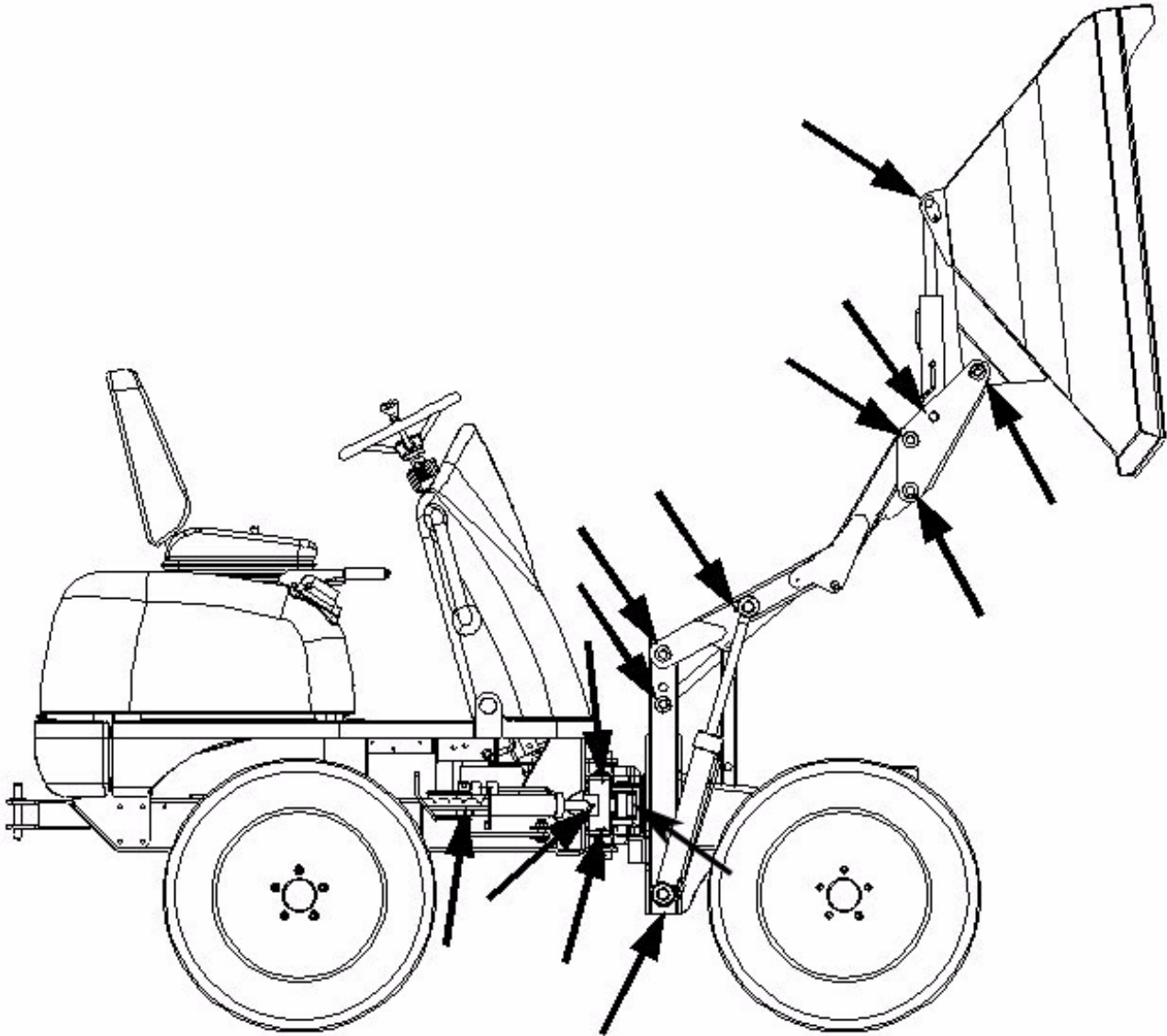
Fold down the red maintenance strut before you carry out maintenance work with the lift frame raised – see *Wartungsstütze* on page 1-8.



Apply multipurpose lithium grease with an MoS<sup>2</sup> additive to all lubrication points indicated.

## 5.18 Lubrication points 1501: overview

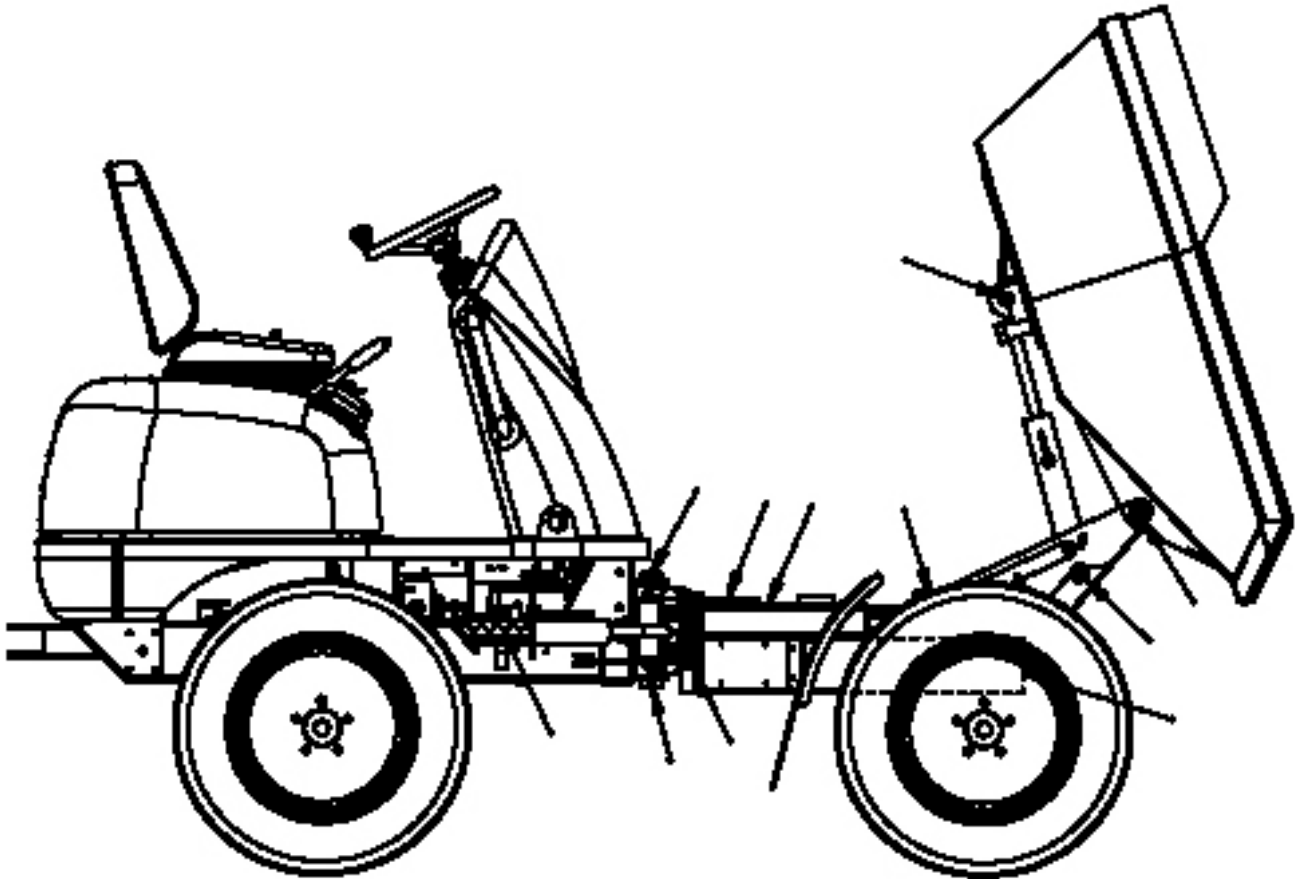
Fold down the red maintenance strut before you carry out maintenance work with the lift frame raised – see *Wartungsstütze Typ 1501* on page 1-10.



Apply multipurpose lithium grease with an MoS<sup>2</sup> additive to all lubrication points indicated.

## 5.19 Lubrication points 1501S: overview

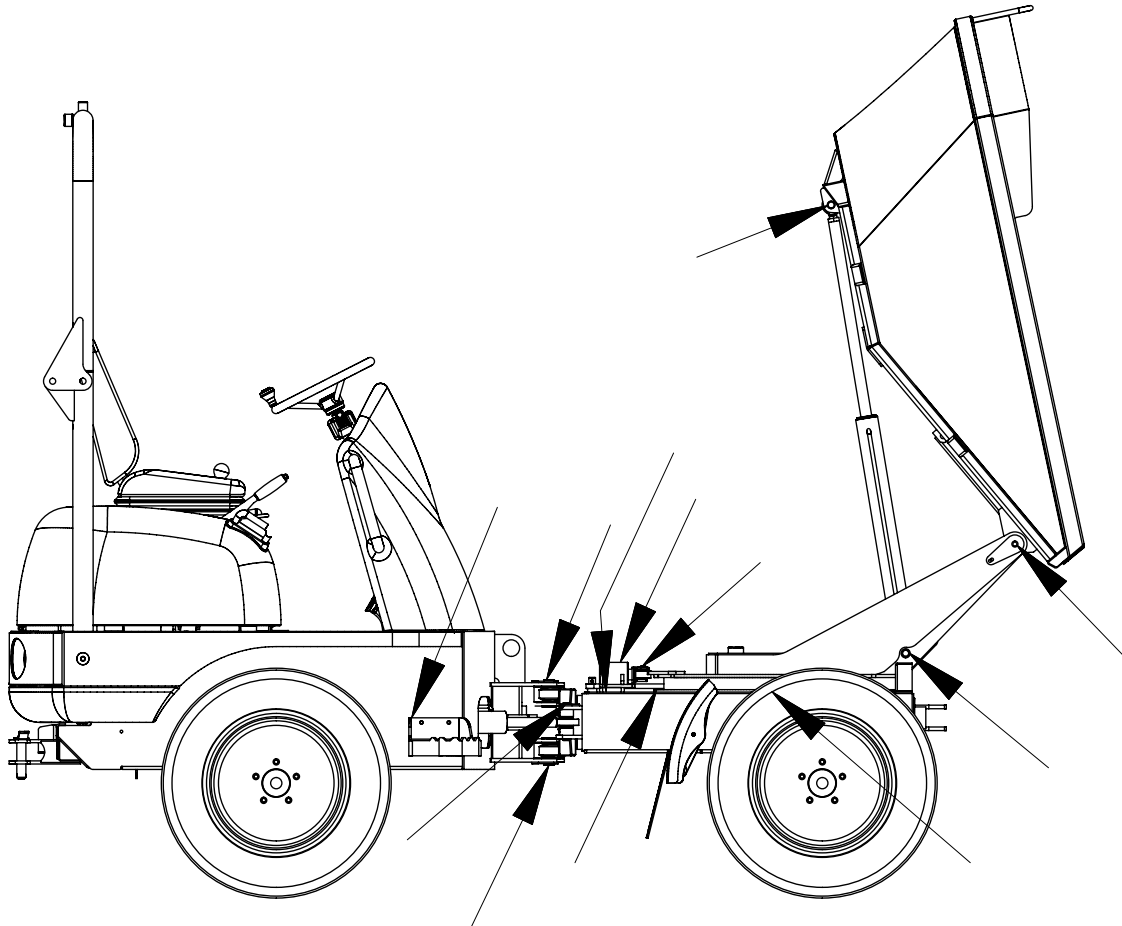
Fold up the red maintenance strut before you carry out maintenance work with the lift frame raised – see *Wartungsstütze Typ 1501* on page 1-10.



Apply multipurpose lithium grease with an MoS<sup>2</sup> additive to all lubrication points indicated.

## 5.20 Lubrication points 2001: overview

Fold down the red maintenance strut before you carry out maintenance work with the skip raised – see *Wartungsstütze* on page 1-8.



Apply multipurpose lithium grease with an MoS<sup>2</sup> additive to all lubrication points indicated





## 6 Specifications (1001 – 1501)

### 6.1 Chassis

Sturdy steel sheet chassis, rubber-mounted engine

### 6.2 Engine

Engine	Model 1001 up to AC000335	From AB100001H
	Models 1501/1501S up to AC000101	From AB150001H/AB150002D
Product	Yanmar diesel engine	Yanmar diesel engine
Type	3TNE74-NSR3	3TNV76-XNSV
Design	Water-cooled 4 stroke diesel engine	Water-cooled 4-stroke diesel engine, EPA2
No. of cylinders	3	3
Fuel injection system	Direct injection	Indirect injection
Aspiration	Natural aspiration	Natural aspiration
Cooling system	Water-cooled	Water-cooled/aspirating fan
Lubrication system	Force-feed lubrication with trochoidal pump	Force-feed lubrication with trochoidal pump
Displacement	1006 cm <sup>3</sup>	1116 cm <sup>3</sup>
Nominal bore and stroke	74 x 78 mm	76 x 82 mm
Output	14 kW at 2500 rpm	17 kW
Max. torque	63 Nm	65.8 Nm at 1600 rpm
Max. engine speed without load	2500 rpm	1001 up to AB101121H: 3000 rpm 1001 from AB101122H: 2900 rpm 1501: 3000 rpm
Idling speed	1100 +/- 25 rpm	1300 +/- 25 rpm
Valve clearance (intake = outlet)	0.15 – 0.25 mm (cold)	0.15 – 0.25 mm (cold)
Compression	23.0 : 1	23.5 : 1
Compression: specified value	35 +/- 1 bar at 250 rpm	35 bar at 250 rpm
Compression: threshold value	27 bar at 250 rpm	28 bar at 250 rpm
Engine oil pressure under full load	3 – 4 bar	0.3 – 0.45 bar
Pressure switch for engine oil pump	0.5 +/- 0.1 bar	0.5 +/- 0.1 bar
Thermostat opens at	69.5 – 72.5 °C	69.5 – 72.5 °C
Thermal switch	107 – 113 °C	107 – 113 °C
Firing order	1 – 3 – 2	1 – 3 – 2
Direction of rotation	Counterclockwise (as seen from the flywheel)	Counterclockwise (as seen from the flywheel)
Starting aid	Glow plug (preheating time 10 – 15 seconds)	Glow plugs (preheating time 4 seconds)
Max. inclined position (engine no longer supplied with oil):	25°/45 % in all directions	25°/46 % in all directions 30°/58 % for 3 minutes Observe the machine's climbing ability (30°/58 %)!)
Specific fuel consumption	279 g/kWh	272 g/kWh
Exhaust values according to	97/68/EC	EPA Tier II

### 6.3 Travelling drive

### 6.4 Brakes

Variable displacement pump		Models 1501/1501S
Design	Axial piston pump	
Displacement	0 – 45 cm <sup>3</sup> /rev	
Flow rate	99 l/min	
Max. operating pressure	360 bar	
Boost pump (integrated in variable displacement pump)		
Design	Gear pump	
Displacement	11.6 cm <sup>3</sup> /rev	
Charging/boost pressure	20 bar	
Service brake/ parking brake	Up to AC000335	From AB150001H AB150002 D
Design	Hydrostatic	Pedal-operated hydrostatic drive brake
Location	Rear hydraulic motors	
Effect	Hydraulic parking brake for auxiliary brake and parking brake with hand brake valve control	

### 6.5 Steering system

Steering system	Models 1501/1501S
Design	Hydrostatic chassis articulation steering with emergency steering features.
Steering mode	Chassis articulation steering

### 6.6 Work hydraulics

Work hydraulics	Models 1501/1501S
Hydraulic pump displacement	8.3 cm <sup>3</sup> /rev
Hydraulic pump flow rate	18 l/min
Control valve	2 sections
Max. operating pressure	170 bar
Secondary pressure limiting for offset ram	165 bar
Hydraulic oil cooler	Standard
Hydraulic tank capacity	20 l

### 6.7 Loader unit

Loader unit	Models 1501/1501S
Skip capacity	650 l struck
	800 l heaped
	420 l liquid capacity
Payload	1500 kg

## 6.8 Drive specifications

Steering system	Models 1501/1501S
Drive speed	0 – 18 kph
Articulation	+/- 33°
Oscillation	+/- 15°
Outside turning radius	3500 mm
Hill climbing ability	45 %
Safe authorised inclination	20 % in all directions

## 6.9 Electrical system (up to AC000101)

Electrical system	
Alternator	12 V 40 A
Starter	12 V 1.1 kW
Battery	12 V 45 Ah

### Fuse box

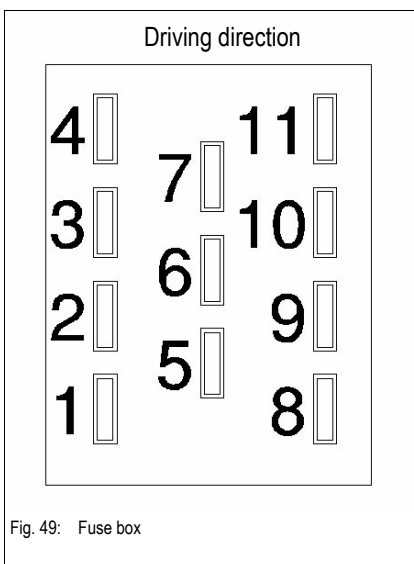


Fig. 49: Fuse box

Fuse no.	Rated current (A)	Protected circuit
1	30 A	– Cutoff solenoid, cutoff solenoid time lag relay
2	7.5 A	– Horn
3	7.5 A	– Alternator governor
4	7.5 A	– Solenoid valve pump
5	7.5 A	– Light switch
6		– Not assigned
7		– Not assigned
8	7.5 A	– Telltales
9		– Not assigned
10		– Not assigned
11		– Not assigned

### Relays

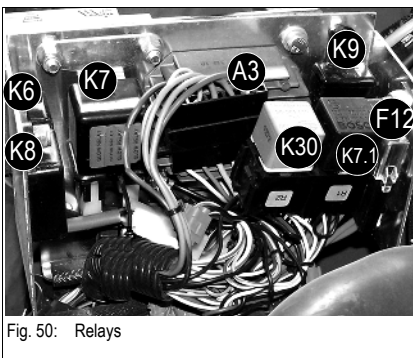


Fig. 50: Relays

The relays are located in the relay box under the control stand, next to the swivelling console

Switching relay no.	Protected circuit
K 6	– Preheating time lag relay
K 8	– Cutoff solenoid time lag relay
K 7	– Start high current relay
K 9	– Cutoff solenoid switching relay
K 30	– Relay for parking brake warning buzzer

K 7.1	– Start interlock relay
A3	– Regulator
F12	– Main fuse

### 6.10 Electrical system (from AB150001H/150002D)

Electrical system	
Alternator	12 V 20 A
Starter	12 V 1.2 kW
Battery	12 V 45 Ah

#### Fuse box

The fuse box is located on the right-hand side of the machine under the engine cover (see arrow).

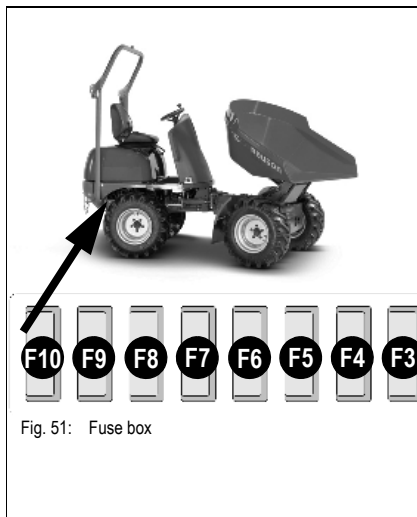


Fig. 51: Fuse box

Fuse no.	Rated current (A)	Protected circuit
F 3	10 A	– Cutoff solenoid, cutoff solenoid time lag relay
F 4	15 A	– Drive solenoid valves
F 5	10 A	– Horn, parking brake, brake lights
F 6	15 A	– Turn indicators
F 7	15 A	– High beam
F 8	10 A	– Low beam
F 9	10 A	– Clearance light
F10	10 A	– Hazard warning system

#### Relays

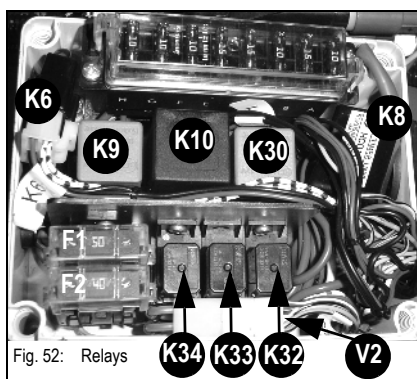


Fig. 52: Relays

Switching relay no.	Protected circuit
K 6	– Preheating time lag relay
K 8	– Cutoff solenoid time lag relay
K 9	– Cutoff solenoid switching relay
K 10	– Turn indicator relay
K 30	– Parking brake relay
K 32	– Start interlock relay
K 33	– Low beam relay
K 34	– High beam relay
V2	– Diodes
F 1, 2	– Main fuses

**6.11 Tyres 1001/1501/2001**

Tyre size	Tyre pressure		Wheel offset
	Front	Rear	
10.00/7.5x15	3 bar	3 bar	20

**6.12 Noise levels**

Sound power level	Up to AC000335	From AB150001H AB150002D
Sound power level (L <sub>WA</sub> )	102 dB (A)	101 dB (A)

**Notice!**

Measurement of sound power level according to EC Directive 2000/14 EC. Noise level at the driver's ear measured according to EC Directives 84/532/EEC, 89/514/EEC and 95/27/EEC.

Measurements carried out on asphalted surface.

**6.13 Coolant compound table**

Outside temperature	Coolant			
	Water	Anticorrosion agent		Antifreeze agent
Up to °C	% by volume	cm <sup>3</sup> /l	% by volume	% by volume
4	99	10	1	–
-10	79			20
-20	65			34
-25	59			40
-30	55			44

### 6.14 Dimensions model 1001

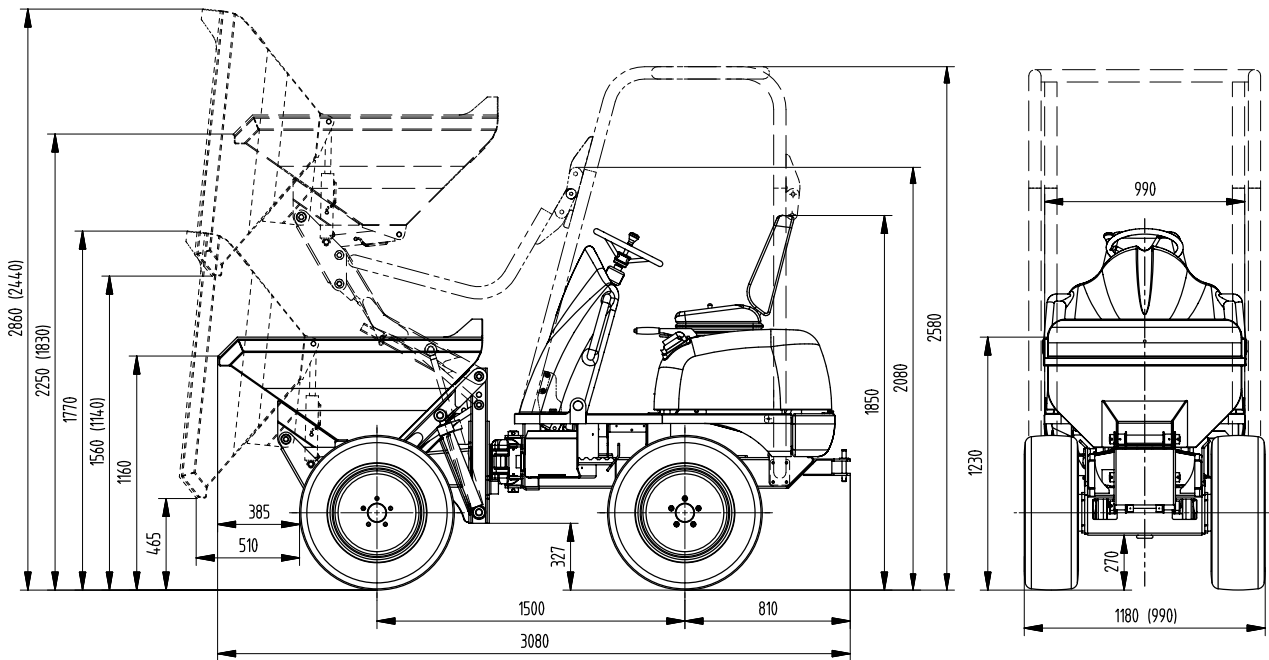


Fig. 53: Machine dimensions (model 1001)

Main data	Model 1001
Dead weight	1165 kg
Overall height	2580 mm
Overall height with rollbar folded down	2080 mm
Overall height without rollbar	1850 mm
Overall width	1180 mm
Overall width (narrow version)	990 mm
Ground clearance	270 mm
Wheelbase	1500 mm
Outside turning radius	3200 mm

## 6.15 Dimensions model 1501

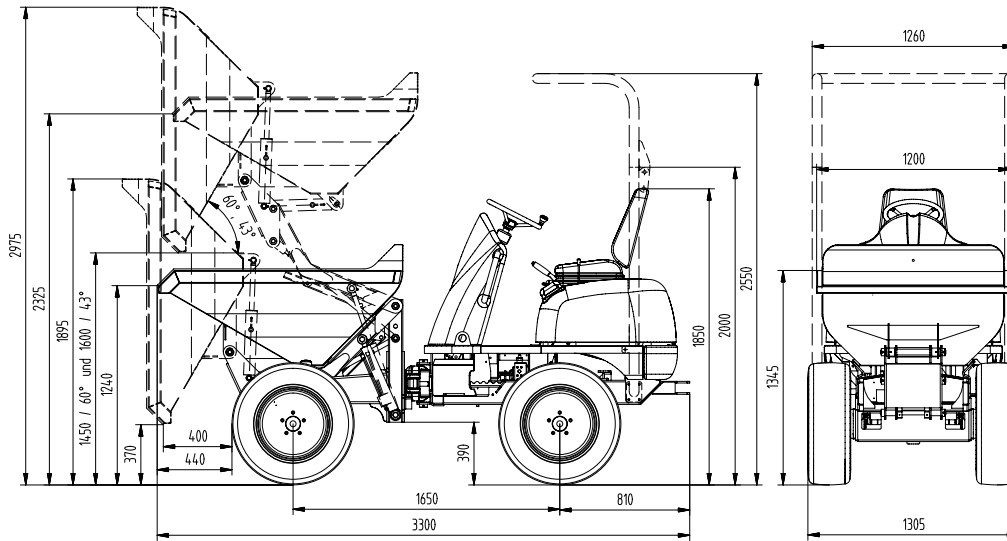


Fig. 54: Machine dimensions (model 1501)

Main data	Model 1501
Dead weight	1226 kg
Overall height	2550 mm
Overall height with rollbar folded down	2000 mm
Overall height without rollbar	1850 mm
Overall width	1305 mm
Ground clearance	270 mm
Wheelbase	1650 mm
Outside turning radius	3500 mm

## 6.16 Dimensions model 1501S

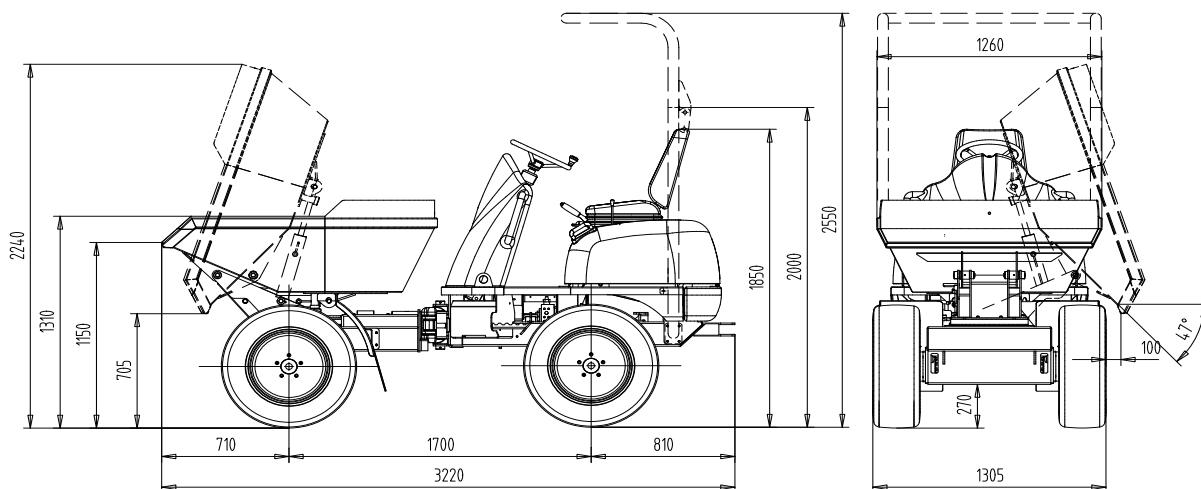


Fig. 55: Machine dimensions (model 1501S)

Main data	Model 1501S
Dead weight	1210 kg
Overall height	2550 mm
Overall height with rollbar folded down	2000 mm
Overall height without rollbar	1850 mm
Overall width	1305 mm
Ground clearance	270 mm
Wheelbase	1700 mm
Outside turning radius	3500 mm





## 6 Specifications (2001)

### 6.1 Engine

Engine	Model 2001	
	Tier 2	Tier 3
Product	Yanmar diesel engine	
Type	3TNV82V-DNSV	3TNV82A-BDNSV
Design	Water-cooled 4 stroke diesel engine	
No. of cylinders	3	
Fuel injection system	Direct injection	
Aspiration	Natural aspiration	
Cooling system	Water-cooled	
Lubrication system	Force-feed lubrication with trochoidal pump	
Displacement	1331 cm <sup>3</sup>	
Nominal bore and stroke	82 x 84 mm	
Output	22.1 kW +/- 3 % at 3000 rpm	22.5 kW +/- 3 % at 3000 rpm
Max. torque	83 Nm at 1800 rpm	84 Nm
Max. engine speed without load	3180 rpm +/- 25 rpm	3000 rpm +/- 25 rpm
Idling speed	~ 1050 rpm +/- 25 rpm	~ 1000 rpm +/- 25 rpm
Valve clearance (intake = outlet)	0.15 – 0.25 mm (cold)	
Injection pressure	220 – 230 bar	200 – 210 bar
Compression	31 +/- 1 bar at 250 rpm	
Engine oil pressure	3 – 4 bar	3.2 – 4.7 bar
Pressure switch for engine oil pump	0.5 +/- 0.1 bar	0.39 – 0.54 bar
Thermostat opening temperature	69.5 – 72.5 °C	70 – 73 °C (fully open at 85 °C)
Thermal switch	107 – 113 °C	
Firing order	1 – 3 – 2	
Direction of rotation	Counterclockwise (as seen from the flywheel)	
Starting aid	Glow plug (preheating time 10 – 15 seconds)	Glow elements (preheating time 10 – 15 seconds)
Max. inclined position (engine no longer supplied with oil):	25°/45 % in all directions	
Exhaust values according to	97/68/EG EPA II	97/68/EC EPA

## 6.2 Travelling drive

Variable displacement pump		Model 2001
Design		Axial piston pump
Displacement		0 – 56 cm <sup>3</sup> /rev
Flow rate		168 l/min
Max. operating pressure		420 bar
Boost pump (integrated in variable displacement pump)		
Design		Gear pump
Displacement		8.3 cm <sup>3</sup>
Charging/boost pressure		25 bar

## 6.3 Brakes

Service brake/parking brake		Model 2001
Design		Hydrostatic and hydraulic parking brake
Function		Effect on hydraulic pump via rotary throttle. In addition, solenoid valve on hydraulic parking brake on front wheel motors
Parking brake		Hydraulic parking brake on all four wheel motors actuated with parking brake valve

## 6.4 Steering system

Steering system		Model 2001
Design		Hydrostatic chassis articulation steering with emergency steering features
Steering mode		Chassis articulation steering

## 6.5 Work hydraulics

Work hydraulics		Model 2001
Hydraulic pump displacement		8.3 cm <sup>3</sup> /rev
Hydraulic pump flow rate		25 l/min
Control valve		2 sections
Max. operating pressure		175 bar
Secondary pressure limiting for offset ram		160 bar
Hydraulic oil cooler		Standard
Hydraulic tank capacity		28 l

## 6.6 Loader unit

Loader unit		Model 2001
Skip capacity		930 l struck
		1210 l heaped
		680 l liquid capacity
Payload		2000 kg

## 6.7 Drive specifications

Steering system	Model 2001
Drive speed	0 – 21 kph
Articulation	+/- 33°
Oscillation	+/- 15°
Outside turning radius	3500 mm
Hill climbing ability	45 %
Safe authorised inclination	20 % in all directions

## 6.8 Electrical system

Electrical system	
Alternator	12 V 40 A
Starter	12 V 1.4 kW
Battery	12 V 74 Ah

### Fuse box

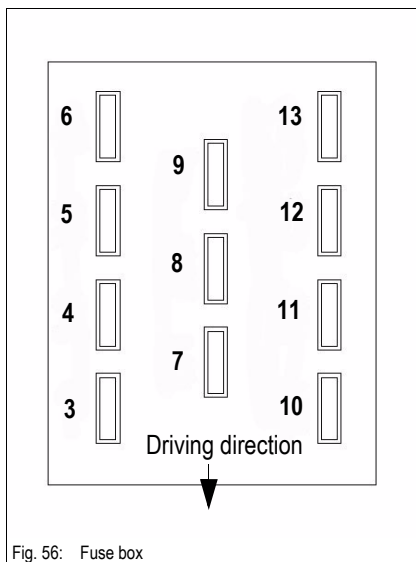


Fig. 56: Fuse box

Fuse number	Rated current (A)	Protected circuit
3	10 A	– Hazard warning system 30
4	7.5 A	– Clearance lights, numberplate lights
5	7.5 A	– Low beam
6	10 A	– High beam
7	7.5	– Not assigned
8	7.5 A	– Horn, brake lights
9	10 A	– Turn indicators, telltales, fuel level indicator, safety relays
10	7.5 A	– Rotating beacon
11	7.5 A	– Travelling drive
12	10 A	– Cutoff solenoid relay
13	20 A	– Cutoff solenoid 30

Relays

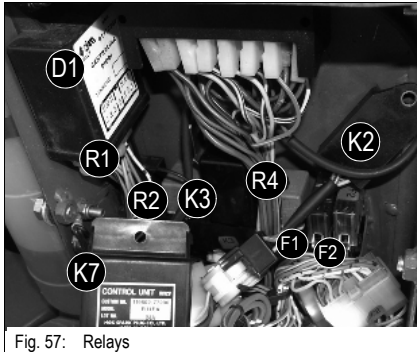


Fig. 57: Relays

The relays are located in the relay box under the cab, next to the swivelling console

Switching relay no.	Protected circuit
F 1	– Main fuse
F 2	– Main fuse
R 1	– Start high current relay
R 2	– Start interlock relay
R 4	– Cutoff solenoid relay
K 2	– Preheating time lag relay
K 3	– Turn indicator relay
K 7	– Safety relay
D1	– Diode box

## 6.9 Tyres

Tyre size	Tyre pressure		Wheel offset
	Front	Rear	
10.00/7.5x15	3 bar	3 bar	20

## 6.10 Noise levels

Sound power level	2001
Sound power level (L <sub>WA</sub> )	101 dB (A)



### Notice!

Measurement of sound power level according to EC Directive 2000/14 EC. Noise level at the driver's ear measured according to EC Directives 84/532/EEC, 89/514/EEC and 95/27/EEC.

Measurements carried out on asphalted surface.

## 6.11 Coolant compound table

Outside temperature	Coolant			
	Water	Anticorrosion agent		Antifreeze agent
Up to °C	% by volume	cm <sup>3</sup> /l	% by volume	% by volume
4	99	10	1	–
-10	79			20
-20	65			34
-25	59			40
-30	55			44

The relays are located in the relay box under the floor panel of the control stand

Switching relay no.	Protected circuit
F1, F2	– Main fuses
K 6	– Preheating time lag relay
K7	– Start high current relay
K 8	– Cutoff solenoid time lag relay
K 9	– Cutoff solenoid switching relay
K 10	– Turn indicator relay
K32	– Start interlock relay
K33	– Low beam relay
K34	– High beam relay
V2	– Diodes

## 6.12 Tyres

Type	Tyre size	Tyre pressure		Load-bearing capacity
		Front	Rear	
2001	11.5/80 x 15.3	3 bar	3 bar	PR 10

## 6.13 Noise levels

Sound power level	3001
Sound power level (L <sub>WA</sub> )	101 dB (A)
Sound pressure level (L <sub>PA</sub> )	85 dB (A)



### Notice!

Measurement of sound power level according to EC Directive 2000/14 EC. Noise level at the driver's ear measured according to EC Directives 84/532/EEC, 89/514/EEC and 95/27/EEC.

Measurements carried out on asphalted surface.

## 6.14 Coolant compound table

Outside temperature	Coolant			
	Water	Anticorrosion agent		Antifreeze agent
Up to °C	% by volume	cm <sup>3</sup> /l	% by volume	% by volume
4	99	10	1	–
-10	79			20
-20	65			34
-25	59			40
-30	55			44

## 6.15 Dimensions model 2001

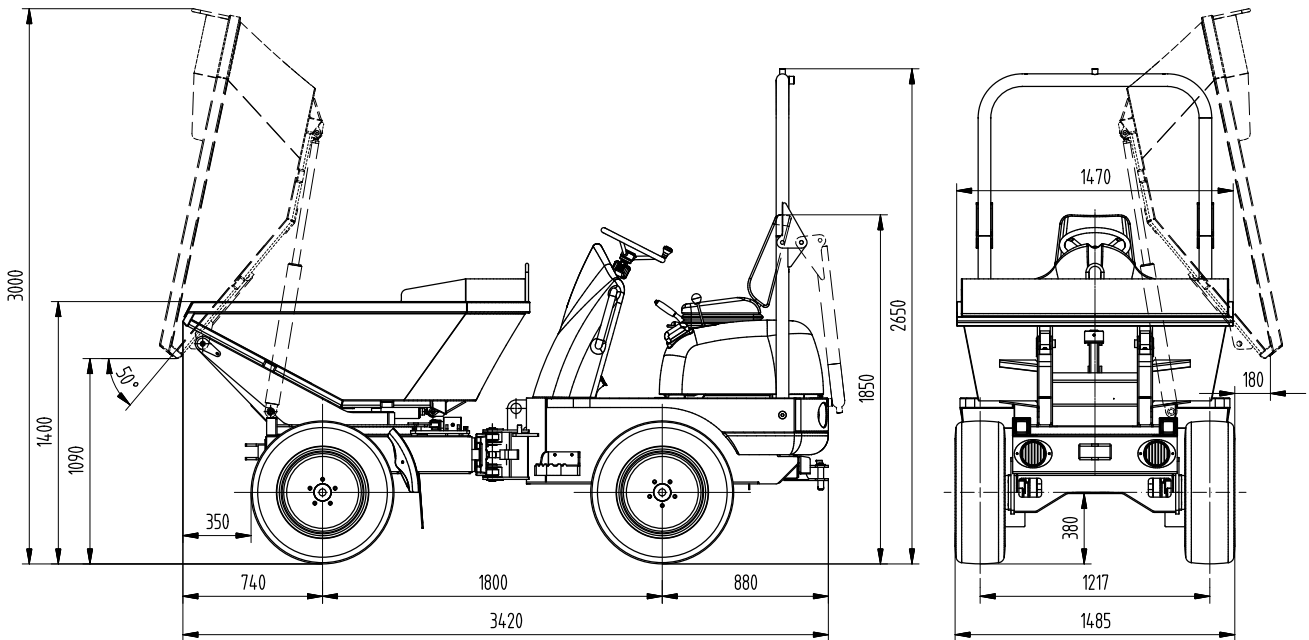


Fig. 58: Machine dimensions (model 2001)

Main data	Model 2001
Dead weight	1810 kg
Overall height	2650 mm
Overall height with rollbar folded down	1850 mm
Overall height without rollbar	1850 mm
Overall width	1485 mm
Ground clearance	380 mm
Wheelbase	1800 mm
Outside turning radius	3500 mm
Hill climbing ability	45 % theoretically
Safe authorised inclination	20 % in all drive positions







## **7 Safety instructions for operation of earth moving machines**

### **7.1 Preliminary remark**

The following machines are designated as earth moving machines:

- Excavators
- Loaders
- Backhoe loaders
- Dozers
- Dumpers
- Scrapers
- Graders
- Pipe laying machines
- Trench cutting machines
- Compactors and
- Other special earthmoving machines.

Instructions for the safe operation of earth moving machines are given in the following.

Also comply with the national safety standards – such as regulations for accident prevention or safety guidelines for machine maintenance – during operation and maintenance of earth moving machines.

In addition to the Operator's Manual, also bear in mind the legal regulations concerning public road traffic and accident prevention. These regulations may also deal with handling hazardous substances or wearing personal protective equipment.

Also bear in mind the existing safety regulations concerning specific work sites (tunnels, day drifts, quarries, pontoons, contaminated areas, etc.).

### **7.2 Designated use**

- 7.2.1 Earth moving machines may be used only in compliance with their designated use, and by following the instructions given in the Operator's Manual of the manufacturer.
- 7.2.2 Designated use means that the earth moving machine is used with the work equipment for work in compliance with the European or national work safety regulations, or that the earth moving machine is used for other work the manufacturer has deemed the machine to be suitable for.
- 7.2.3 The operator may not carry out any safety-relevant modifications on the earth moving machine without the manufacturer's authorisation.
- 7.2.4 Spare parts must comply with the technical requirements specified by the manufacturer.



### 7.3 General

- 7.3.1 Earth moving machines may be driven and serviced only by persons who meet the following requirements:
- Physically and mentally suited for this work
  - Persons have been instructed in driving or servicing the earth moving machine and have proven their qualifications to the contractor.
  - Persons are expected to carry out work reliably.
- Observe statutory minimum age limits.
- 7.3.2 Avoid any operational mode that might be prejudicial to safety.
- 7.3.3 Do not exceed the authorised load of the earth moving machine.
- 7.3.4 Operate the earth moving machine only in a safe and reliable state.
- 7.3.5 Follow the instructions given in the Operator's Manual of the manufacturer for all work involving operation, maintenance, repair, assembly and transport.
- 7.3.6 If necessary, the operator must supplement the safety instructions by specific instructions adapted to the local conditions of the work site.
- 7.3.7 The Operator's Manual and safety-relevant instructions must be carefully stored in the control stand. The manual and the safety instructions can be stored at the work site itself if the earth moving machine has no cab.
- 7.3.8 The Operator's Manual and the safety instructions must be complete and legible.
- 7.3.9 Do not disable the function of the earth moving machine's safety equipment during operation.
- 7.3.10 Wear protective work clothes during work. Avoid wearing rings, scarves, unzipped or unbuttoned jackets. Specific work can require wearing protective goggles, safety shoes, a hard hat, protective gloves, reflective vests, ear protectors, etc.
- 7.3.11 Get informed on first aid and rescue possibilities (emergency physician, fire brigade, helicopter) before starting work.
- Check whether the first-aid kit is installed and whether its contents are in compliance with regulations.
- 7.3.12 You must be familiar with the location and the operation of fire extinguishers on the earth moving machine, and with the local fire alarm and fire fighting facilities.
- 7.3.13 Secure loose parts, such tools or other equipment, on the earth moving machine.
- 7.3.14 Secure open doors, windows, covers, lids, etc., to prevent them from closing unintentionally.



## **7.4 Danger area**

- 7.4.1 All persons must stay clear of the danger area of the earth moving machine.  
The danger area is the area around the earth moving machine in which persons are at risk by work-specific movements of the earth moving machine, its work equipment and attachments, by slewing or falling material, or by falling work equipment.
- 7.4.2 The machine operator may work with the earth moving machine only if no-one is in the danger area.
- 7.4.3 The machine operator must give warning signs in case of danger for persons.
- 7.4.4 The machine operator must stop work with the earth moving machine if persons do not leave the danger area in spite of his warnings.
- 7.4.5 Do not step onto the articulation of articulation-steered earth moving machines if the engine is running.
- 7.4.6 Keep a sufficiently safe distance (min. 500 mm) to fixed elements of construction, e.g. buildings, walls to be pulled down, scaffolds or other machines to avoid danger of crushing.
- 7.4.7 If a safe distance cannot be kept, seal off the area between fixed elements of construction and the work range of the earth moving machine.
- 7.4.8 If the operator's visibility onto his drive and work range is impaired by work-specific circumstances, instruct the operator or seal off the drive and work range with a fixed barrier.

## **7.5 Stability**

- 7.5.1 Always use, drive and operate the earth moving machine ensuring stability and safety from turning over (see also item 7.3).
- 7.5.2 The operator must adapt his drive speed to the prevailing conditions and lower the work equipment the closest possible to the ground when driving on sloping or uneven terrain.
- 7.5.3 Follow the instructions given in the specific sections of the Operator's Manual of the manufacturer when using an earth moving machine equipped with additional outriggers or supporting equipment for increasing stability.
- 7.5.4 Keep the earth moving machine at a safe distance from the edges of quarries, pits, ditches, slopes or embankments to avoid danger of falling.
- 7.5.5 When driving or working near excavations, shafts, trenches or the edge of pits and embankments, secure the earth moving machine to prevent it slipping or rolling away.



## 7.6 Operation

### 7.6.1 General

7.6.1.1 Machine operators must be appointed by the contractor for driving and servicing the earth moving machine.

7.6.1.2 Controls (operating elements) may be actuated by the driver or from the driver's seat only.

7.6.1.3 Use the footholds and surfaces provided for to access the machine. Keep them clean to ensure a safe hold at all times.

7.6.1.4 If the work equipment of the earth moving machine can be picked up and set down with a quickhitch, the lock of which cannot be easily seen from the driver's seat for reasons of design or dirt, take the following additional safety measures:

- The driver or another person must make sure that the work equipment is firmly hitched by checking the quickhitch connection itself.
- If this is not possible, raise the work equipment only until you can check it is firmly hitched by dumping it in and out.

All other persons must stay clear of the danger area during this check.

### 7.6.2 Transporting persons

7.6.2.1 Apart from the driver, persons may be transported on earth moving machines only if specific places have been provided for by the manufacturer.

These places must be provided with firm seats and restraints to prevent falling off the earth moving machine.

7.6.2.2 Persons may access or leave the earth moving machine only after the machine operator has allowed them to do so, and only after the machine is at a standstill.

### 7.6.3 Drive operation

7.6.3.1 In order to ensure safe work, adjust the seat, the rearview mirrors and the controls before putting the earth moving machine into operation.

7.6.3.2 Fasten the seat belt if the earth moving machine is fitted with a rollover protection structure (ROPS).

7.6.3.3 The windows must be clean and free of mist or ice.

7.6.3.4 Do not use cold-starting aids (ether) near heat sources, naked flames or in poorly ventilated premises.

7.6.3.5 The layout of roads and paths must ensure smooth and safe operation, i.e. they must be sufficiently wide, have sufficient load-bearing capacity and the slightest possible slopes.

7.6.3.6 Observe the load-bearing capacity of bridges, basement ceilings, vaults etc., before moving the machine on them!

7.6.3.7 Bear in mind the clear widths and heights of underpasses, tunnels, etc. before driving through them.

7.6.3.8 When driving on steep slopes, carry loads on the uphill side, if possible, in order to increase stability.

7.6.3.9 Do not drive downhill with the clutch disengaged. Shift to a gear adapted to the terrain before driving down a slope, and do not shift gears on the slope.



- 7.6.3.10 When driving on slopes, select a route that will enable you to brake the earth moving machine safely.
- 7.6.3.11 Avoid reversing over longer distances.
- 7.6.3.12 Earth moving machines may be driven on public roads only if the operating and driving licences as defined by national traffic regulations have been obtained for them.
- 7.6.3.13 When not driving on public roads, e.g. construction sites, apply the road traffic rules accordingly. This also applies to driving permits.
- 7.6.4 Load and unloading
  - 7.6.4.1 The machine operator may move the work equipment across persons in driver seats or work stations of other machines only if they are protected by canopies (FOPS).
  - 7.6.4.2 If not protected accordingly, the driver of this vehicle must leave the operator's place if moving the work equipment across his place cannot be avoided.
  - 7.6.4.3 When loading vehicles, make sure they are not overloaded and that they will not loose any material when driving. Load them from the lowest possible height.
  - 7.6.4.4 If possible, the places where material is unloaded should enable the driver to avoid reversing over longer distances.
  - 7.6.4.5 At places where material is dumped, operate earth moving machines only after having taken appropriate measures to prevent the machines from falling down or rolling away under their own weight.
- 7.6.5 Persons giving instructions
  - 7.6.5.1 Persons giving instructions must be easily visible, e.g. by means of high-visibility warning clothes. They must maintain visual contact with the machine operator.
  - 7.6.5.2 When carrying out their duty, persons giving instructions must not be assigned other tasks that could distract them from their duty.
- 7.6.6 Operation with risk of falling objects
  - 7.6.6.1 In case of danger of heavy objects falling down, use earth moving machines only if the driver's seat is equipped with a canopy (FOPS), and with an additional front protection in the case of excavators.
  - 7.6.6.2 When working in front of earth and rock walls, if possible position and operate the earth moving machine with the control stand and the access to the control stand facing the side opposite the wall.
  - 7.6.6.3 Demolition work may be carried out with earth moving machines only if no persons are at risk.
  - 7.6.6.4 When carrying out demolition work with excavators (e.g. with demolition balls), make sure the weight of the ball matches the boom length and the load-bearing capacity of the machine.
  - 7.6.6.5 If possible, the highest point of the work equipment of the earth moving machine must be higher than structure to be demolished.



- 7.6.7 Working in the area of underground electric lines
- 7.6.7.1 Before excavating with earth moving machines, find out whether there are any underground electric lines in the work area that might put persons at risk.
- 7.6.7.2 If there are underground electric lines, determine the positions and the routing of these lines, and define and carry out the required safety measures after having agreed upon these activities with the owner or operator of the lines.
- 7.6.7.3 Before starting excavation work, clearly mark the routing of lines in the area of the construction site in the presence of the owner or operator. If the position of lines cannot be determined, dig trenches to search for the lines (by hand if necessary).
- 7.6.7.4 If the machine operator damages or unexpectedly comes across underground electric lines or their protective covers, he must stop work immediately and inform the person supervising the activities.
- 7.6.8 Working next to overhead electric lines
- 7.6.8.1 When working next to overhead electric lines and contact lines with the earth moving machine, maintain a safe distance (depending on the rated voltage of the lines) between these lines and the earth moving machine and its work equipment in order to avoid any current transfer. This also applies to the distance between these lines and attachments or loads.
- 7.6.8.2 The following safe distances apply in Germany:

Rated voltage	Safe distance
Up to 1000 V	1.0 m
Over 1 kV to 110 kV	3.0 m
Over 110 kV to 220 kV	4.0 m
Over 220 kV to 380 kV	
Or unknown rated voltage	5.0 m

- 7.6.8.3 In doing so, also bear in mind all work movements of the earth moving machine, e.g. boom positions, swinging of ropes and the size of hitched loads. Also bear in mind uneven ground resulting in an inclined position, and hence in a shorter distance of the earth moving machine to overhead electric lines.
- Both overhead electric lines and the work equipment can be deflected even by slight wind, resulting in a reduced distance to the lines.
- 7.6.8.4 If no sufficient distance can be kept to overhead electric lines and contact lines, the contractor must take other safety measures to avoid current transfer after having agreed upon these activities with the owner or operator of the lines. This can be achieved, for instance, by
- switching off the current,
  - re-routing the overhead electric line,
  - protecting overhead electric lines by installing them underground or
  - limiting the work range of the earth moving machine.



- 7.6.8.5 In case of a current transfer or if the machine touches a live wire, the following rules apply:
- Do not leave the control stand
  - Warn others against approaching and touching the machine
  - If possible, move the work equipment or the entire earth moving machine out of the danger area
  - Have the live wire de-energised!
  - Leave the machine only after the damaged line/the line you have come into contact with is de-energised.
- 7.6.9 Operation below ground and in enclosed areas
- When using earth moving machines below ground and in enclosed areas, ensure adequate ventilation and follow the regulations that are in force.
- 7.6.10 Breaks/work interruptions
- 7.6.10.1 During breaks and at the end of a shift, the driver must park the earth moving machine on firm and level ground and secure the machine against unintentional movements.
- Lower the work equipment to the ground or secure it in order to prevent unintentional movements.
- 7.6.10.2 The driver may not leave the earth moving machine if the work equipment has not been secured or lowered to the ground.
- 7.6.10.3 Park the earth moving machine only in places where it will not pose an obstacle, e.g. to traffic on public roads or construction sites.
- If necessary, install warning devices, such as warning triangles, warning tape, flashing or warning lights, etc.
- 7.6.10.4 The driver must move all controls to their zero positions and apply the brakes before leaving the control stand.
- 7.6.10.5 The driver must stop the engines and secure them against unauthorised start-up if he goes away from the earth moving machine.
- 7.6.11 Applications with lifting gear
- 7.6.11.1 Applications with lifting gear are understood as procedures involving raising, transporting and lowering loads with the help of slings and load-securing devices (ropes, chains, etc.). In doing so, the help of persons is necessary for securing and detaching the load.
- This applies for example to lifting and lowering pipes, shaft rings or containers with earth moving machines.
- 7.6.11.2 The earth moving machine may be used for applications with lifting gear only if the prescribed safety devices are in place and functional.
- In the case of hydraulic excavators, these are for example:
- Safe possibilities of slinging and securing lifting gear
  - Load diagram
  - And in addition, for hydraulic excavators with an authorised load of over 1000 kg or an overturning moment of over 40 000 Nm
  - Safe load indicator
  - Hose burst valve(s) on the boom lift ram(s)



- 7.6.11.3 The load must be secured so as to prevent it from falling or slipping.
- 7.6.11.4 Persons guiding the load or securing it must stay in visual contact with the machine operator.
- 7.6.11.5 The machine operator must guide the load the nearest possible to the ground and avoid any oscillating or swinging movements!
- 7.6.11.6 The earth moving machine may be driven with a raised load only if the path of the machine is as level as possible!
- 7.6.11.7 When using earth moving machines for lifting gear applications, the persons attaching or securing loads may approach the boom from the side only, and only after the machine operator has given his permission. The machine operator may give his permission only after the machine is at a standstill and the work attachment no longer moves!
- 7.6.11.8 Do not use any lifting gear (ropes, chains) which is damaged or not sufficiently dimensioned. Always wear protective gloves when working with lifting gear.

## 7.7 Assembly, maintenance, repair

- 7.7.1 The earth moving machine may be assembled, modified or disassembled only in accordance with the Operator's Manual of the manufacturer and only under the supervision of suitable staff appointed by the contractor.
- 7.7.2 For instance, work on the
- Brake
  - Steering
  - Hydraulic and
  - Electrical systems
- of the earth moving machine may be carried out only by specially trained staff.
- 7.7.3 Stability must be ensured at all times during maintenance work.
- 7.7.4 Secure the work equipment against movement by lowering it to the ground or by taking appropriate measures, e.g. supporting brackets or sleeves. If necessary, secure the upper carriage of the excavator against rotation.
- 7.7.5 When carrying out maintenance and repair work on an earth moving machine with an articulated joint, secure the joint with a positive lock when working in the area of the articulated joint.
- 7.7.6 When installing or removing counterweights, hitch them only at the points provided for by the manufacturer.
- 7.7.7 When jacking up the earth moving machine, place the lifting device in a position that will avoid slipping. Installing or placing the lifting device in inclined positions is not permissible.
- 7.7.8 Secure the raised earth moving machine by supporting it with, for instance, supporting frames or trestles, or with boards or square beams stacked crosswise.
- Safely prop the earth moving machine immediately after it has been raised with the work equipment. Working under a raised earth moving machine that is held only by the hydraulics is not permissible.





- 7.7.9 Before replacing the bucket blades of scrapers, make sure the buckets are set down on a base avoiding tipping or damage.
- 7.7.10 Maintenance and repair work on scraper buckets may be carried out only if the lock flap is secured.
- 7.7.11 Switch off all drives before carrying out maintenance and repair work.  
An exception to this requirement is maintenance and repair work that cannot be carried out without a drive. In case of danger, it must be possible to switch off the drive immediately during this work.
- 7.7.12 Disconnect the battery before carrying out arc welding or before working on the electrical system of an earth moving machine fitted with an internal combustion engine.
- 7.7.13 First remove the negative terminal, and then the positive terminal as you disconnect the battery. Proceed in the reverse order as you reconnect the battery.
- 7.7.14 Cover the battery with insulating material as you carry out repair work in the area of the battery; do not place any tools whatsoever on the battery.
- 7.7.15 In the case of earth moving machines with electric drives, switch off the electric equipment and if necessary, the movable connecting lines as well, and secure against unintentional or unauthorised start-up.
- 7.7.16 Open or remove protective devices of moving machine parts only if the drive has been switched off and secured against unauthorised start-up.  
Protective devices are e.g. engine covers, doors, protective screens, trims, etc.
- 7.7.17 Fit all the protective devices back on again correctly once assembly, maintenance or repair work is over.
- 7.7.18 Welding work on load-bearing elements of the earth moving machine, e.g. lattice booms, loader units, may be carried out only in compliance with the acknowledged welding regulations.
- 7.7.19 Do not carry out any welding, boring or drilling on rollover protection structures (ROPS) or canopies (FOPS) that could affect the stability of this equipment.
- 7.7.20 Any modification, such as welding the hydraulic or compressed-air system, may be carried out only with the manufacturer's authorisation.
- 7.7.21 Before starting work on the hydraulic system, release the control and the back pressures, and the pressure inside the tank.
- 7.7.22 Use only the hoses and lines prescribed by the manufacturer.
- 7.7.23 Install and route hydraulic hoses and lines correctly.
- 7.7.24 No smoking and no naked flames during refuelling.



### 7.8 Towing and transporting

- 7.8.1 Tow the earth moving machine only with a towing facility of sufficient size.
- 7.8.2 Use the towing points, such as eyelets, hooks, etc., prescribed by the manufacturer.
- 7.8.3 Move off slowly when towing. All persons must stay clear of the towing facility.
- 7.8.4 When loading and transporting the earth moving machine, secure the machine itself and the auxiliary means against unintentional movements.
- 7.8.5 Remove mud, snow and ice from the running gear and the undercarriage of the earth moving machine in order to ensure safe driving on ramps with no danger of slipping.
- 7.8.6 Place wooden boards on the access ramps of flat-bed trailers before driving on them with tracked machines.
- 7.8.7 Inspect the planned route before moving off, to make sure the roads are sufficiently wide, that bridges and clearances are of sufficient size and that the roads, paths and bridges have sufficient load-bearing capacity.

### 7.9 Monitoring

- 7.9.1 Adhere to the prescribed intervals for routine checks.
- 7.9.2 Before every work shift, the driver must also check the function of the safety, drive and work equipment, such as the safe load indicator, brakes, steering system and lights in accordance with the manufacturer's instructions.
- When installing work equipment onto the quickhitch, make sure the work equipment is firmly hitched by moving it in all positions. In doing so, all persons must stay clear of the danger area.
- 7.9.3 Replace hydraulic hoses as soon as the following damage is detected:
- Damage on the outside layer up to the inner ply
  - Embrittlement on the outside layer
  - Deformations in pressurised or unpressurised state which do not correspond to the original shape of the installed hose
  - Leaks
  - Damage on the hose fittings or on the connection between the fitting and the hose
  - Damage due to storage (storage time of a hose must be under 2 years)
  - Damage due to use beyond the service life (service life is no longer than 6 years if used under normal load).
- 7.9.4 Check the coolant level only after the filler cap has cooled down. Open the cap carefully to release overpressure.



- 7.9.5 The driver must immediately report damage to the person supervising the activities. If drivers change, he must also report to the next driver.
- 7.9.6 In case of defects affecting the operational safety of the earth moving machine, put the machine out of operation until the defects have been remedied.

Wacker Neuson Linz GmbH keep abreast of the latest technical developments and constantly improve their products. For this reason, we may from time to time need to make changes to diagrams and descriptions in this documentation which do not reflect products which have already been delivered and which will not be implemented on these machines. Technical data, dimensions and weights are given as an indication only. Responsibility for errors or omissions not accepted.

No reproduction or translation of this publication, in whole or part, without the written consent of Wacker Neuson Linz GmbH.

All rights under the provision of the Copyright Act are reserved.

Wacker Neuson Linz GmbH  
Haidfeldstr. 37  
A-4060 Linz-Leonding  
Austria

**Wacker Neuson Linz GmbH**  
Haidfeldstr. 37  
A-4060 Linz-Leonding  
Austria  
Tel.: +43 (0) 732 90 5 90-0  
Fax: +43 (0) 732 90 5 90-200  
E-mail: [verkauf@wackerneuson.com](mailto:verkauf@wackerneuson.com)  
[www.wackerneuson.com](http://www.wackerneuson.com)

Order no. 1000103795  
Language En